

System and component information DMCI

XF105

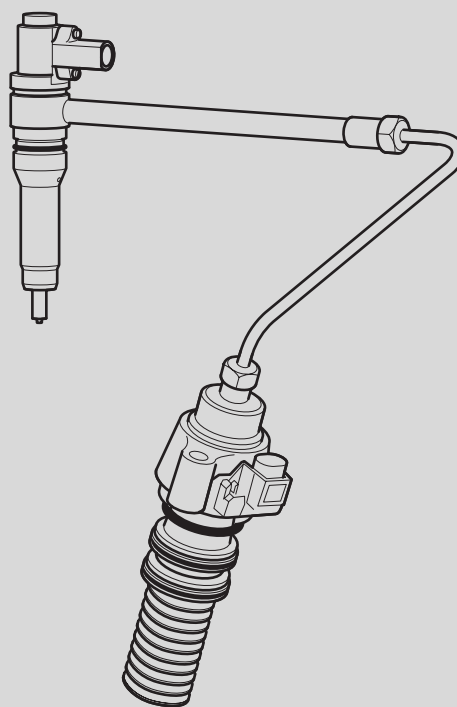

©200528 DAF Trucks N.V., Eindhoven,
The Netherlands.

In the interest of continuing product development,
DAF reserves the right to change specifications
or products at any time without prior notice.

No part of this publication may be reproduced
and/or published by printing, by photocopying, on
microfilm or in any way whatsoever without the
prior consent in writing of DAF Trucks N.V.

STRUCTURE

XF105 series

TECHNICAL DATA

0

DMCI ENGINE MANAGEMENT SYSTEM

1

CONTENTS

	Page	Date
1. DMCI ENGINE MANAGEMENT SYSTEM	1-1	200528
1.1 Power supply and earth of DMCI electronic unit	1-1	200528
1.2 DMCI electronic unit CAN connections	1-2	200528
1.3 Status signals DMCI electronic unit	1-3	200528
1.4 Accelerator pedal sensor	1-4	200528
1.5 Coolant temperature sensor	1-6	200528
1.6 2 nd coolant temperature sensor	1-8	200528
1.7 Inlet air boost pressure and temperature sensor	1-10	200528
1.8 Fuel pressure and temperature sensor	1-13	200528
1.9 Engine oil pressure and temperature sensor	1-16	200528
1.10 Crankshaft sensor	1-19	200528
1.11 Camshaft sensor	1-21	200528
1.12 Engine oil level sensor	1-23	200528
1.13 Switches (manual gearbox)	1-25	200528
1.14 Switches (AS Tronic)	1-26	200528
1.15 Extra bulkhead lead-through functions	1-27	200528
1.16 Red warning	1-28	200528
1.17 Starter motor	1-29	200528
1.18 Glow components	1-30	200528
1.19 Waste gate valve	1-31	200528
1.20 Exhaust brake valve	1-33	200528
1.21 DEB solenoid valve	1-34	200528
1.22 Pump unit	1-36	200528
1.23 Injector	1-38	200528
1.24 Electronically controlled fan clutch	1-40	200528



TECHNICAL DATA

Contents

XF105 series

0

1. DMCI ENGINE MANAGEMENT SYSTEM

1.1 POWER SUPPLY AND EARTH OF DMCI ELECTRONIC UNIT

0

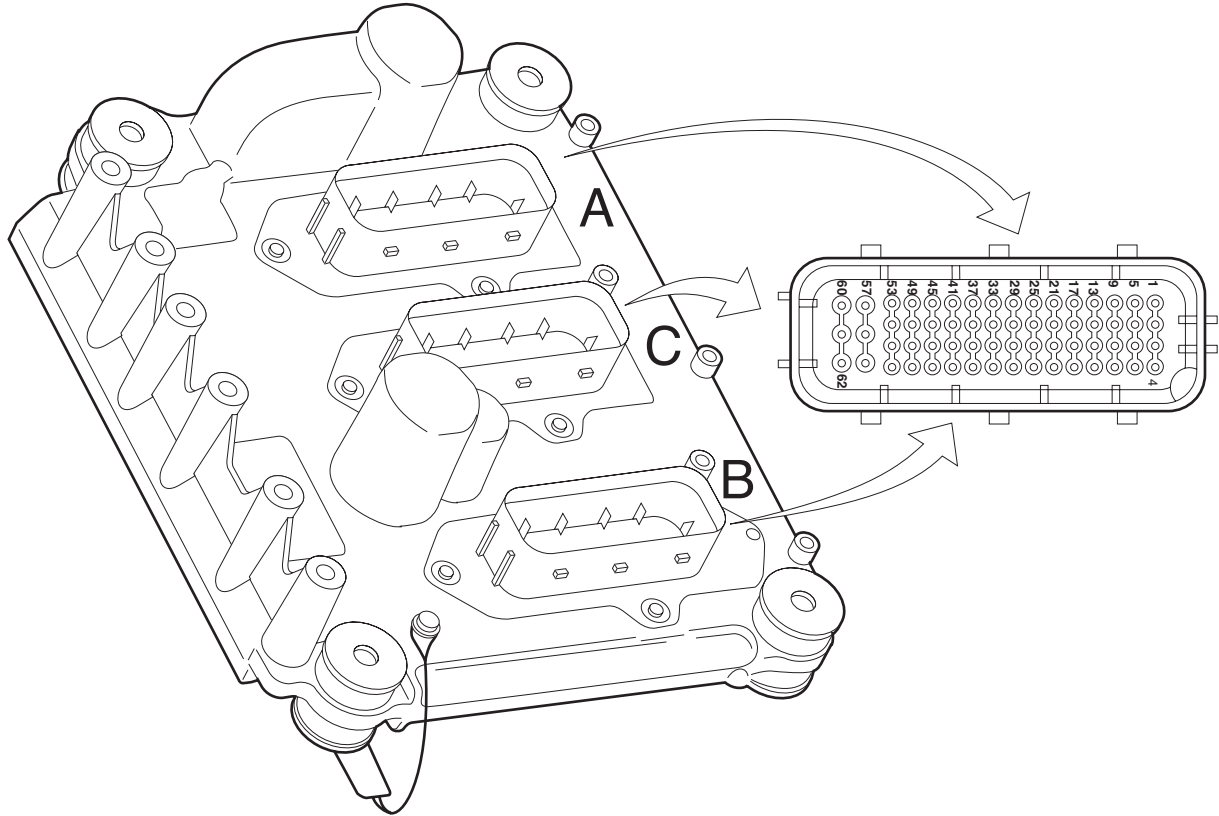

i400726

A	Electronic unit connection point				
B	Description of connection point				
C	Reading at connection point (Ubat = battery voltage)				
D	Measuring unit				
E	Explanatory notes (if applicable)				
F	Additional information available in Technical Data at "X" mark				
A	B	C	D	E	F
B44	Power supply after ignition (G426)	Ubat	V DC	Ignition on	
B57	Earth	< 0.5	VDC	Voltage loss measurement with as many consumers as possible switched on.	
B58	Earth	< 0.5	VDC	Voltage loss measurement with as many consumers as possible switched on.	
B59	Earth	< 0.5	VDC	Voltage loss measurement with as many consumers as possible switched on.	
B60	Power supply before ignition (G126)	Ubat	VDC		
B61	Power supply before ignition (G126)	Ubat	VDC		
B62	Power supply before ignition (G126)	Ubat	VDC		

TECHNICAL DATA

DMCI engine management system

XF105 series

0

1.2 DMCI ELECTRONIC UNIT CAN CONNECTIONS

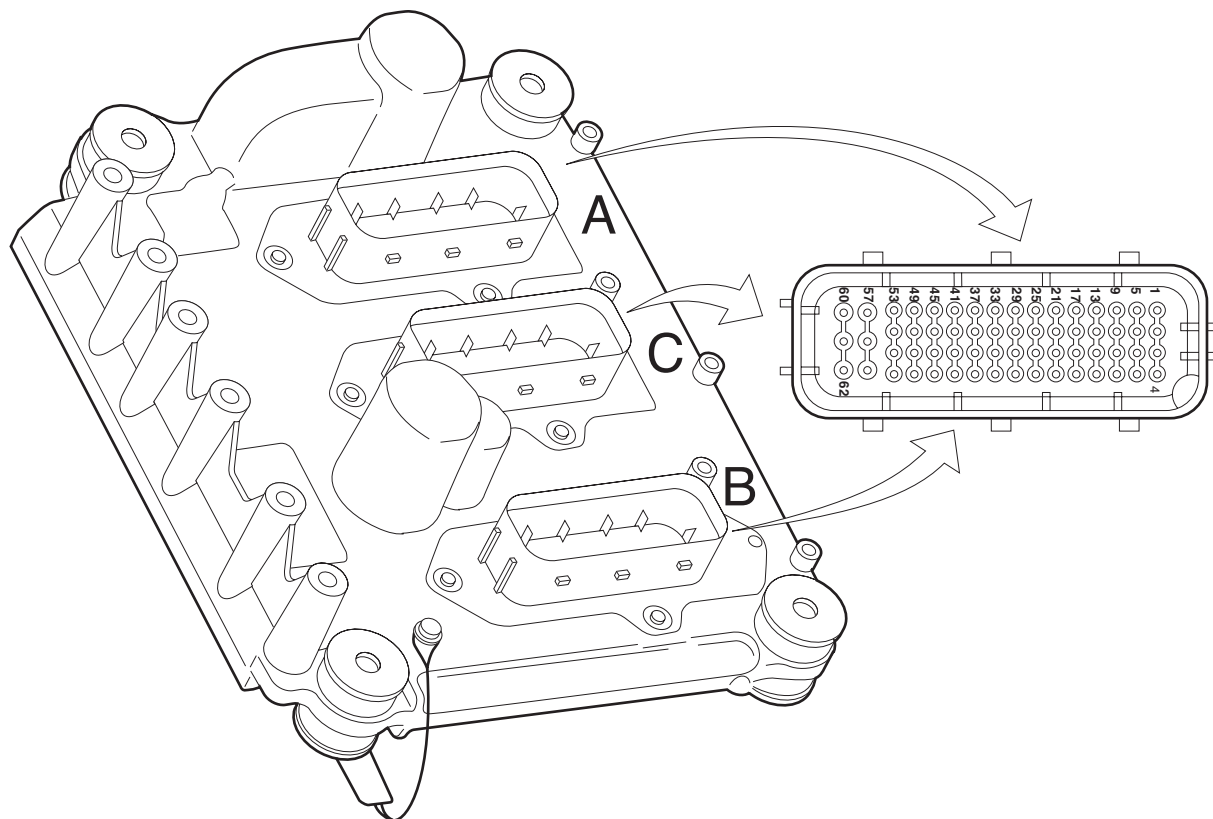

i400726

A	Electronic unit connection point				
B	Description of connection point				
C	Reading at connection point (U _{bat} = battery voltage)				
D	Measuring unit				
E	Explanatory notes (if applicable)				
F	Additional information available in Technical Data at "X" mark				
A	B	C	D	E	F
B27	V-CAN1-H			According to ISO 11898	
B35	V-CAN1-L			According to ISO 11898	
B42	V-CAN1 through connection			According to ISO 11898	
B45	V-CAN2-H			According to ISO 11898	X
B46	V-CAN1 terminating resistance through connection			According to ISO 11898	X
B50	V-CAN1 through connection			According to ISO 11898	X
B53	V-CAN2-L			According to ISO 11898	X
B54	V-CAN1 terminating resistance through connection			According to ISO 11898	

V-CAN1 terminating resistance ±120 Ω ⁽¹⁾
 V-CAN2 terminating resistance ±120 Ω ⁽²⁾

(1) Check the resistance by measuring at connection points B46 and B50 of the electronic unit.
 (2) Check the resistance by measuring at connection points B45 and B53 of the electronic unit.

1.3 STATUS SIGNALS DMCI ELECTRONIC UNIT

0

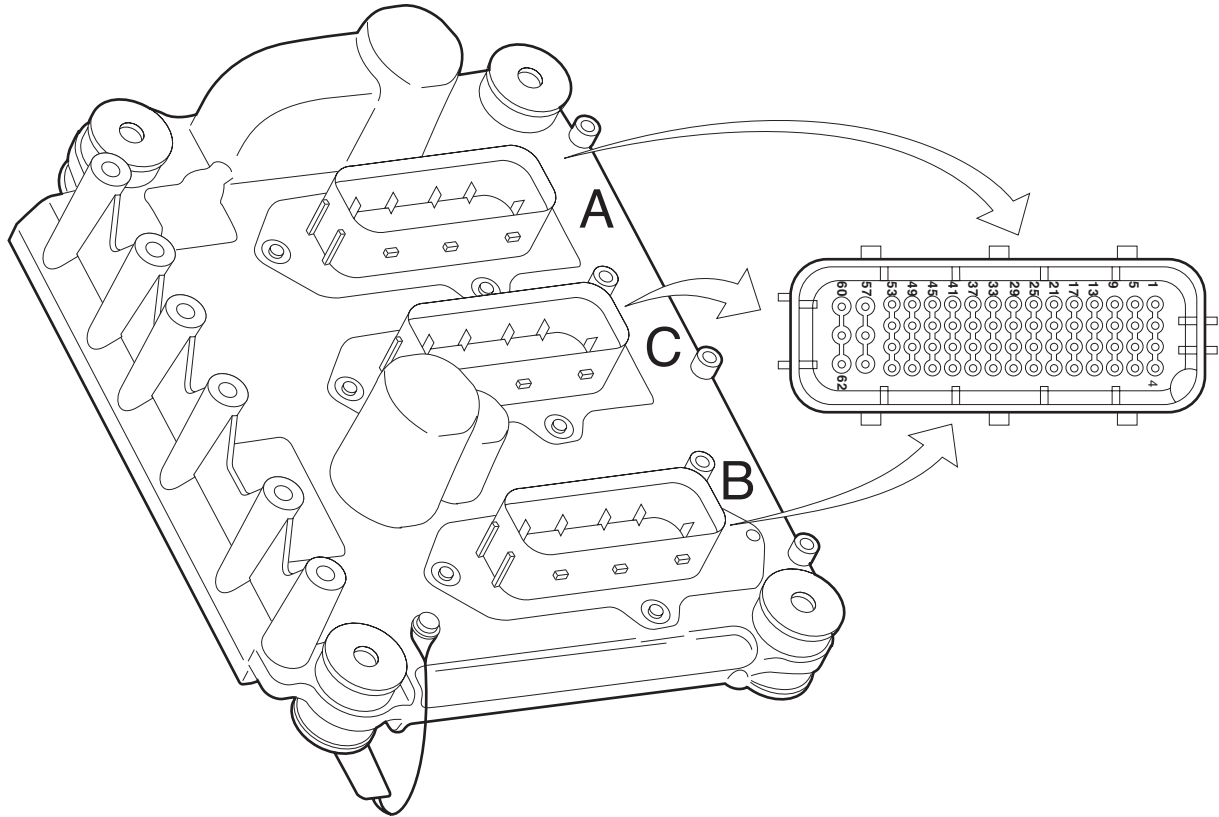

i400726

A	Electronic unit connection point				
B	Description of connection point				
C	Reading at connection point (U _{bat} = battery voltage)				
D	Measuring unit				
E	Explanatory notes (if applicable)				
F	Additional information available in Technical Data at "X" mark				
A	B	C	D	E	F
B51	Input signal, service brake (G469)	U _{bat}	V DC	Brake pedal not operated	
		0	V DC	Brake pedal operated	

TECHNICAL DATA

DMCI engine management system

XF105 series

0

1.4 ACCELERATOR PEDAL SENSOR

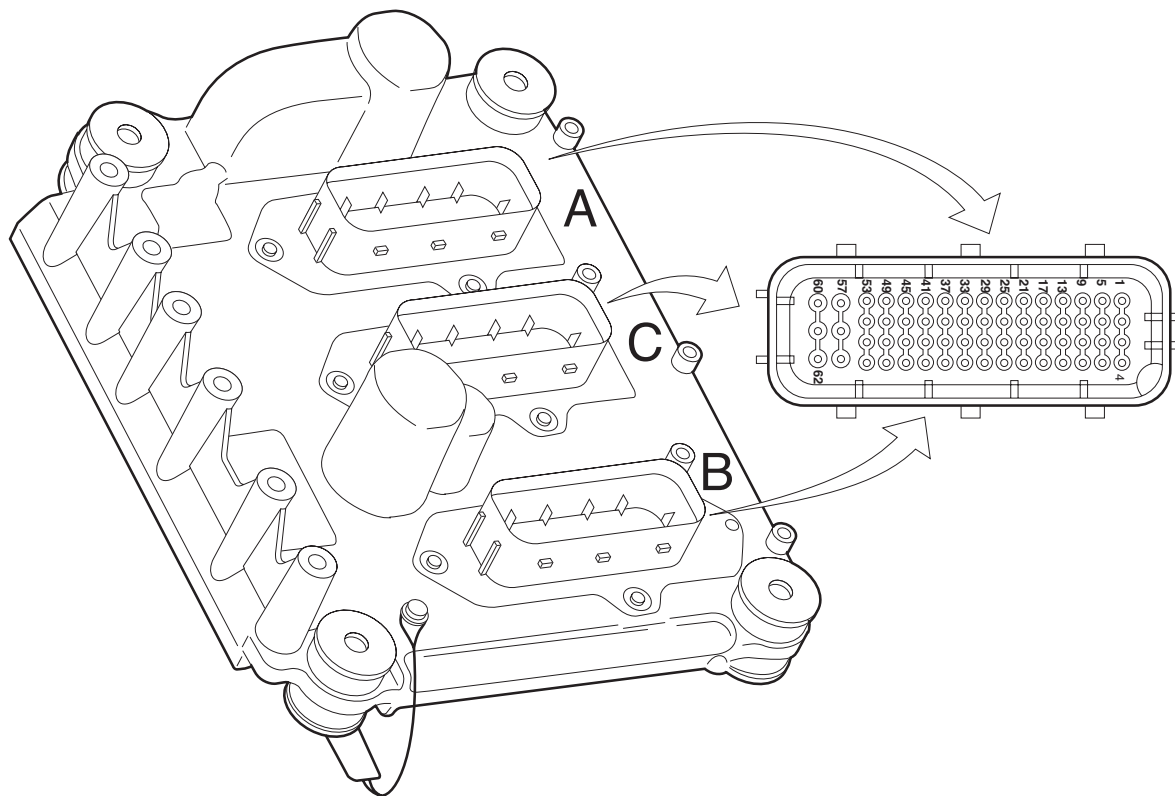

i400726

A	Electronic unit connection point				
B	Description of connection point				
C	Reading at connection point (Ubat = battery voltage)				
D	Measuring unit				
E	Explanatory notes (if applicable)				
F	Additional information available in Technical Data at "X" mark				
A	B	C	D	E	F
B33	Input signal accelerator pedal sensor (F672)	0.325 - 0.500	V DC	Idling, accelerator pedal not operated (0%)	X
		0.675 - 0.875	V DC	Switching point idling switch (circa 10%)	X
		3.000 - 3.400	V DC	Full load (circa 85%)	X
		3.550 - 4.265	V DC	Kickdown (circa 100%)	X
B34	Power supply, accelerator pedal sensor (F672)	5	V DC		
B37	Earth, accelerator pedal sensor (F672)	0	V DC		
B38	Accelerator pedal sensor earth, idling switch (F672)	0	V DC		
B41	Accelerator pedal sensor input signal, idling switch (F672)	5	V DC	Accelerator pedal not operated	X
		0	V DC	Accelerator pedal operated circa 10%	X

TECHNICAL DATA

XF105 series

DMCI engine management system

Potentiometer resistance value (B - C) ⁽¹⁾	1000Ω ± 40%
Potentiometer output resistance value (A - B) ⁽¹⁾	1500Ω ± 40%
Potentiometer output resistance value (A - C) ⁽¹⁾	2500Ω ± 40%
Resistance value across idling switch (open position)	∞
Resistance value across idling switch (closed position) ⁽²⁾	1000Ω ± 40%

(1) Accelerator pedal not operated
 (2) Accelerator pedal operated

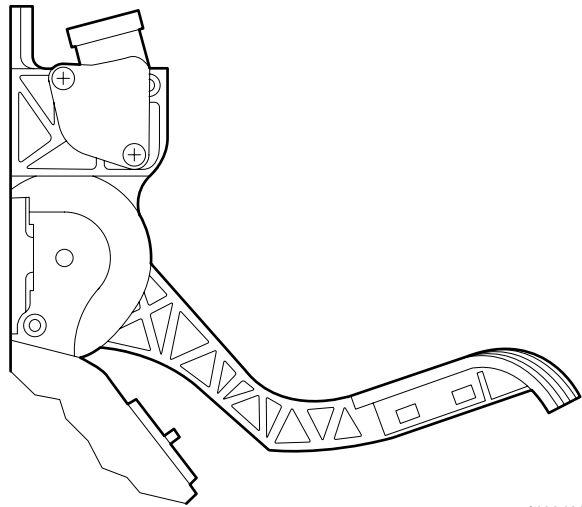
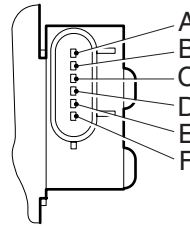

I400438

- A. Potentiometer signal
- B. Mass
- C. Potentiometer supply voltage
- D. Idling switch earth
- E. Not in use
- F. Idling switch signal

TECHNICAL DATA

DMCI engine management system

XF105 series

0

1.5 COOLANT TEMPERATURE SENSOR

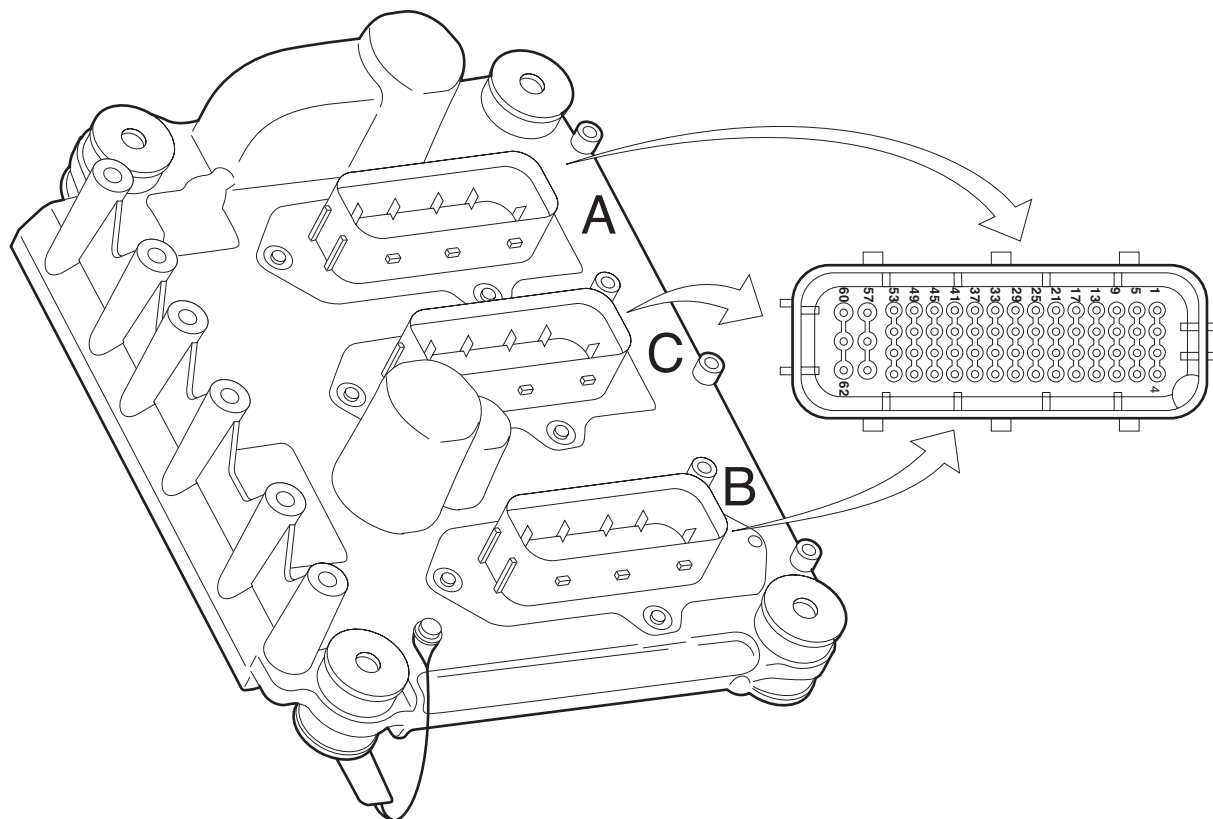

i400726

A	Electronic unit connection point				
B	Description of connection point				
C	Reading at connection point (Ubat = battery voltage)				
D	Measuring unit				
E	Explanatory notes (if applicable)				
F	Additional information available in Technical Data at "X" mark				
A	B	C	D	E	F
C25	Input signal, coolant temperature (F566)	5	V DC	Open voltage, with detached connector	X
C26	Earth, coolant temperature sensor (F566)	0	V DC		

TECHNICAL DATA

XF105 series

DMCI engine management system

Coolant temperature sensor
Model NTC

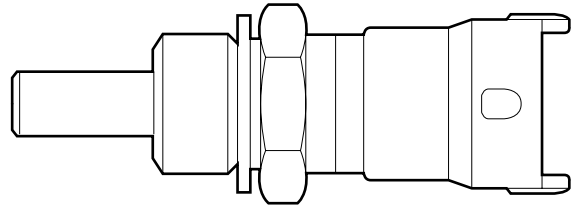

0

i 400440

Resistance in relation to measured temperature ⁽¹⁾

Temperature (°C)	Resistance (Ω)	
	Minimum	Maximum
- 40	38313	52926
- 30	22307	30194
-20	13402	17718
-10	8244	10661
0	5227	6623
10	3390	4217
20	2262	2760
25	1870	2260
30	1553	1866
40	1080	1277
50	771	900
60	555	639
70	408	465
80	304	342
90	230	257
100	178	196
110	136	152
120	106	119
130	84	95
140	67	76

(1) Check the resistance by measuring on the connection points of the sensor.

TECHNICAL DATA

DMCI engine management system

XF105 series

0

1.6 2nd COOLANT TEMPERATURE SENSOR

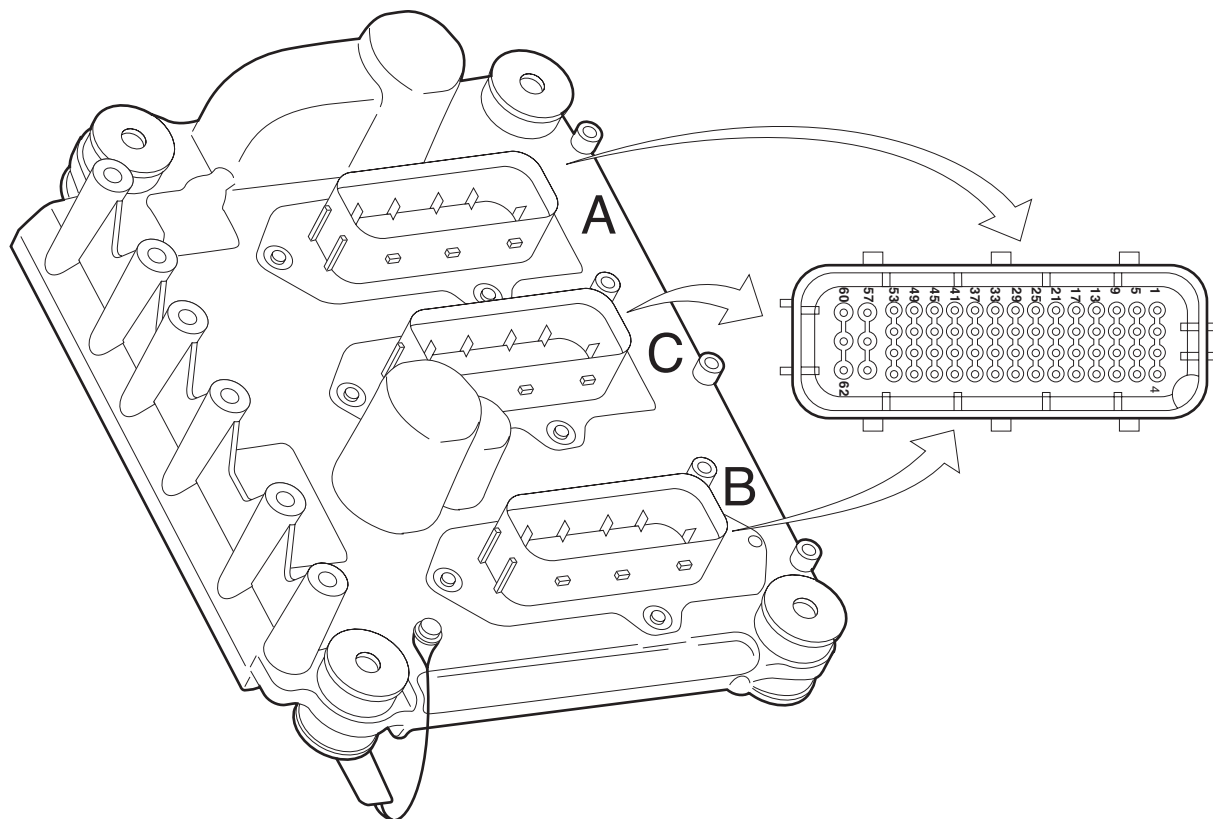

i400726

A	Electronic unit connection point				
B	Description of connection point				
C	Reading at connection point (Ubat = battery voltage)				
D	Measuring unit				
E	Explanatory notes (if applicable)				
F	Additional information available in Technical Data at "X" mark				
A	B	C	D	E	F
A37	Input signal, coolant temperature (F743)	5	V DC	Open voltage, with detached connector	X
A38	Earth, coolant temperature sensor (F743)	0	V DC		

TECHNICAL DATA

XF105 series

DMCI engine management system

Resistance in relation to measured temperature

Temperature (°C)	Resistance (Ω)	
	Minimum	Maximum
- 40	87134	98852
- 30	44876	50910
-20	24215	27471
-10	13703	15545
0	7914	8978
10	4752	5390
20	2948	3344
40	1224	1388
50	8167	927
60	558	632
70	390	442
80	278	311
90	201	227
100	148	168
110	110	124
120	83	95

0

Coolant temperature sensor
Model NTC

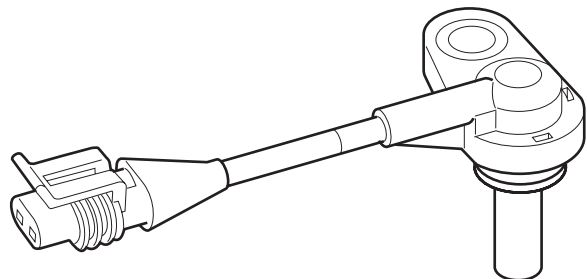

i401003

TECHNICAL DATA

DMCI engine management system

XF105 series

0

1.7 INLET AIR BOOST PRESSURE AND TEMPERATURE SENSOR

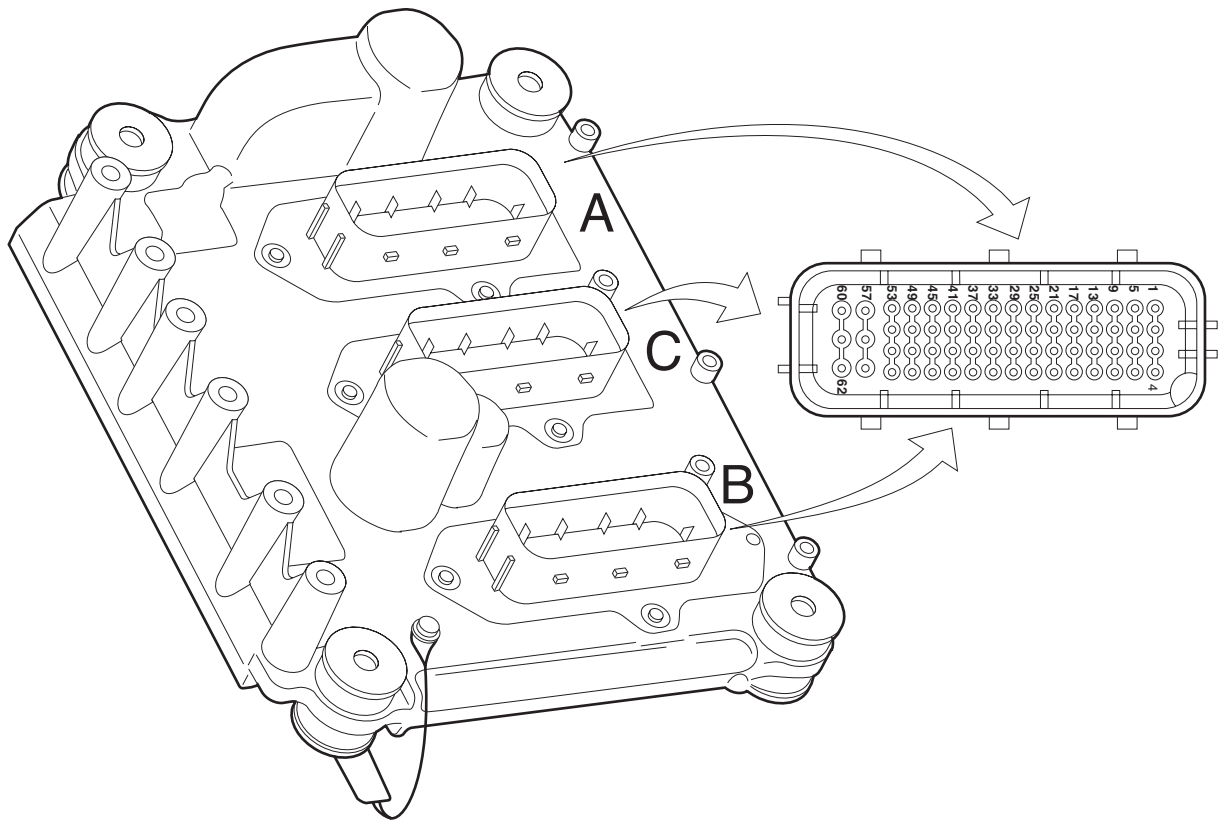

i400726

A	Electronic unit connection point				
B	Description of connection point				
C	Reading at connection point (Ubat = battery voltage)				
D	Measuring unit				
E	Explanatory notes (if applicable)				
F	Additional information available in Technical Data at "X" mark				
A	B	C	D	E	F
A27	Earth air inlet boost pressure and temperature sensor (F649)	0	V DC		
A28	Supply voltage air inlet boost pressure and temperature sensor (F649)	5	V DC	Open voltage, with detached connector	
A30	Input signal air inlet boost pressure (F649)	0.5	V DC	Air inlet pressure 0 bar	X
		4.5	V DC	Air inlet pressure 4 bar	X
A34	Input signal air inlet temperature (F649)	5	V DC	Open voltage, with detached connector	X

TECHNICAL DATA

XF105 series

DMCI engine management system

Colour of O-ring	green
Type of temperature sensor	NTC
Resistance value	See table

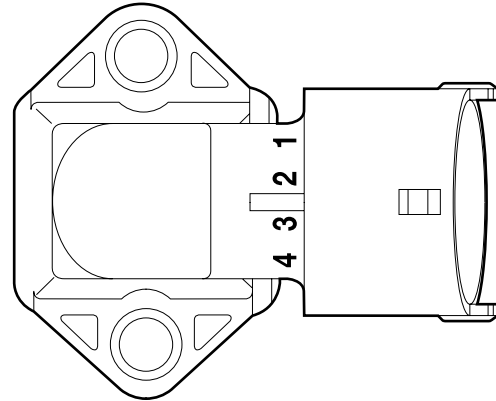
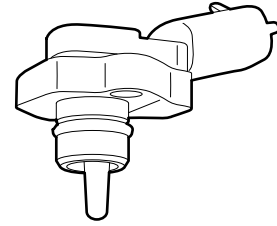

i 400441

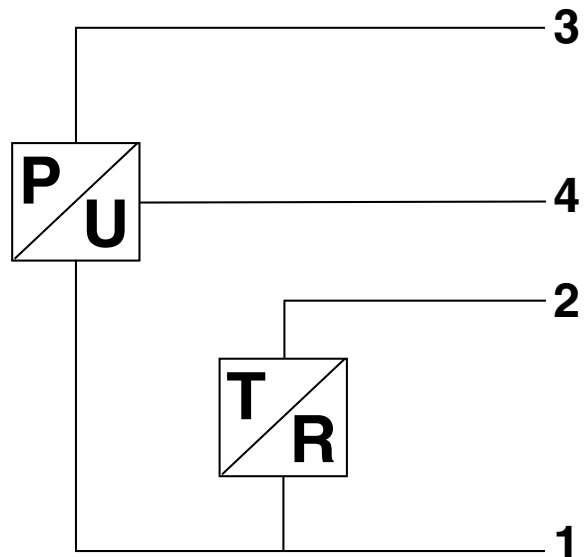

i400534

1. Mass
2. Temperature sensor output signal
3. Pressure sensor supply voltage
4. Pressure sensor output signal

TECHNICAL DATA

DMCI engine management system

XF105 series

0

Resistance in relation to measured temperature ⁽¹⁾

Temperature (°C)	Resistance (Ω)	
	Minimum	Maximum
- 40	38313	52926
- 30	22307	30194
-20	13402	17718
-10	8244	10661
0	5227	6623
10	3390	4217
20	2262	2760
25	1870	2260
30	1553	1866
40	1080	1277
50	771	900
60	555	639
70	408	465
80	304	342
90	230	257
100	178	196
110	136	152
120	106	119
130	84	95
140	67	76

(1) Check the resistance by measuring on connection points 1 and 2 of the sensor.

Type of pressure sensor
Pressure sensor output signal

piezoresistive
See graph

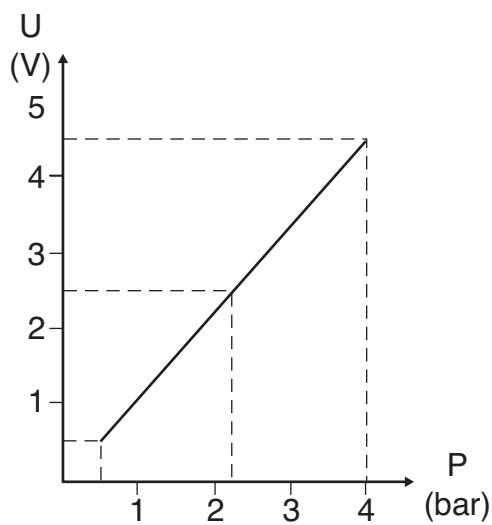

i400836

1.8 FUEL PRESSURE AND TEMPERATURE SENSOR

0

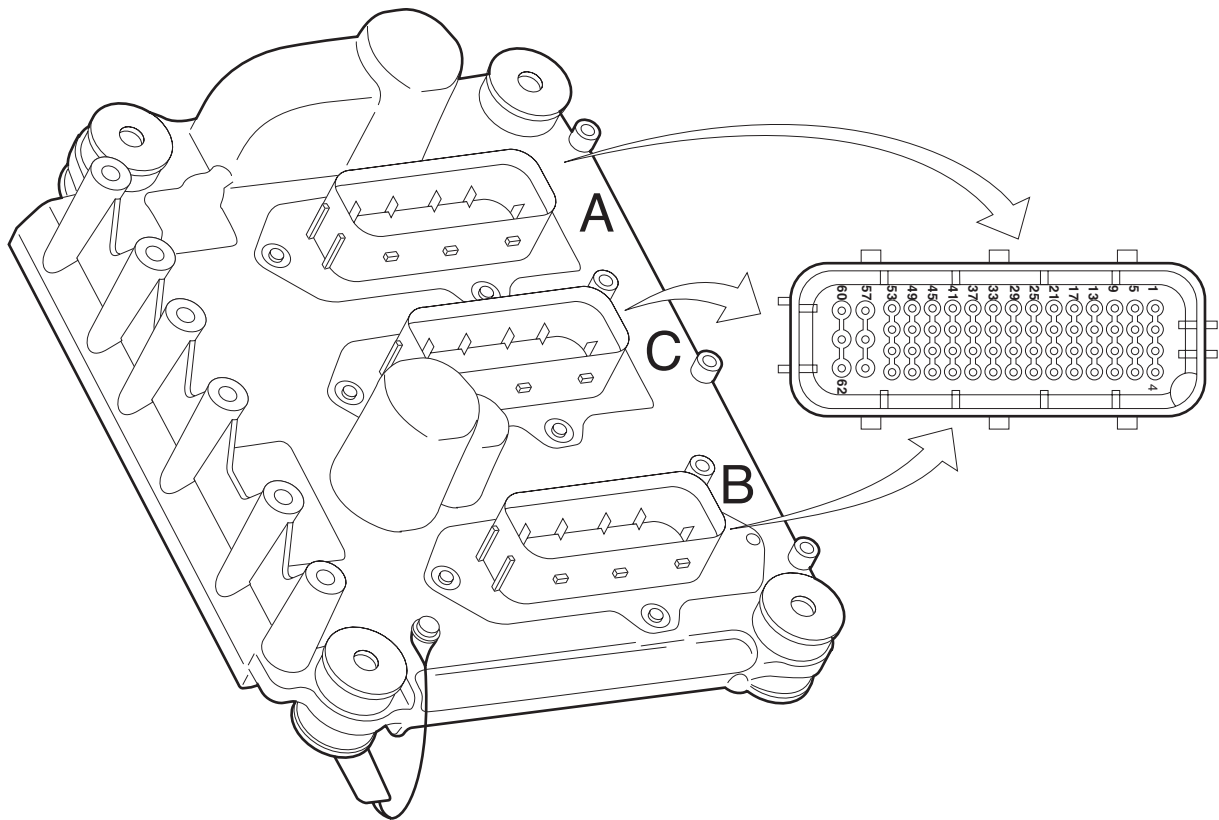

i400726

A	Electronic unit connection point				
B	Description of connection point				
C	Reading at connection point (Ubat = battery voltage)				
D	Measuring unit				
E	Explanatory notes (if applicable)				
F	Additional information available in Technical Data at "X" mark				
A	B	C	D	E	F
A41	Input signal fuel temperature (F713).	5	V DC	Open voltage, with detached connector	X
A42	Supply voltage fuel pressure and temperature sensor (F713)	5	V DC	Open voltage, with detached connector	
A45	Input signal fuel pressure (F713)	0.5	V DC	Fuel pressure 0 bar	X
		4.5	V DC	Fuel pressure 15 bar	X
A46	Earth, fuel pressure and temperature sensor (F713)	0	V DC		

TECHNICAL DATA

DMCI engine management system

XF105 series

0

Gasket

Copper ring

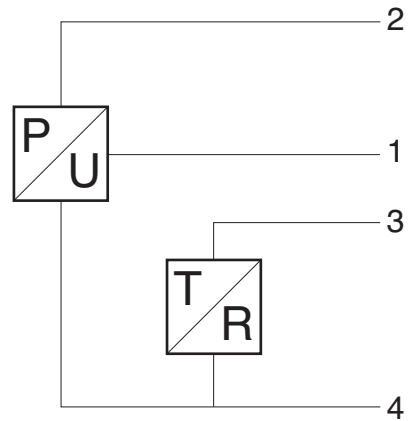

i400791

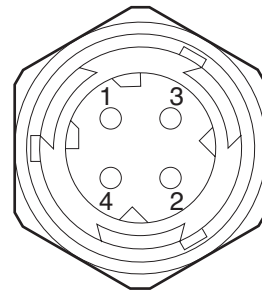
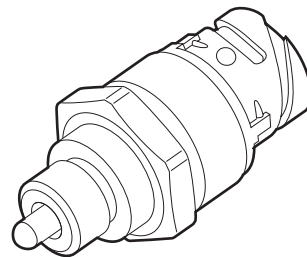

i400792

- 1. Pressure sensor supply voltage
- 2. Pressure sensor output signal
- 3. Temperature sensor output signal
- 4. Mass

Type of temperature sensor

NTC

TECHNICAL DATA

XF105 series

DMCI engine management system

Temperature sensor resistance value ⁽¹⁾

Temperature (°C)	Resistance (Ω)	
	Minimum	Maximum
- 30	24351	30653.2
- 20	13431	16594
- 10	7850	9095
0	4488	5372
10	2740	3236
20	1727	2010
30	1120	1291
40	746	850
50	510	574
60	355	396
70	253	279
80	185	198
90	134	145
100	100	107
110	75	81
120	57	62
130	44	48

(1) Check the resistance by measuring on connection points 3 and 4 of the sensor.

Type of pressure sensor piezo-capacitive

Voltage signal pressure sensor

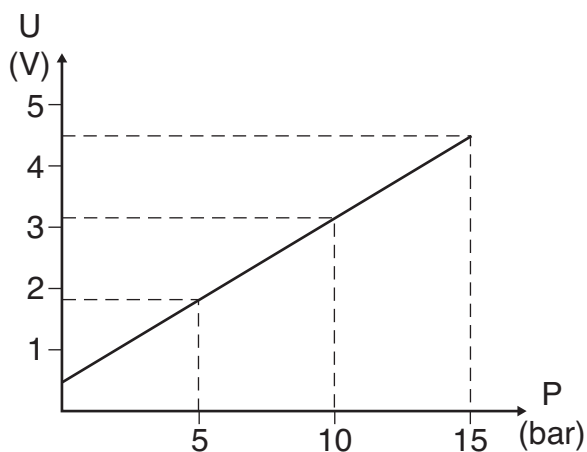

i400835

TECHNICAL DATA

DMCI engine management system

XF105 series

0

1.9 ENGINE OIL PRESSURE AND TEMPERATURE SENSOR

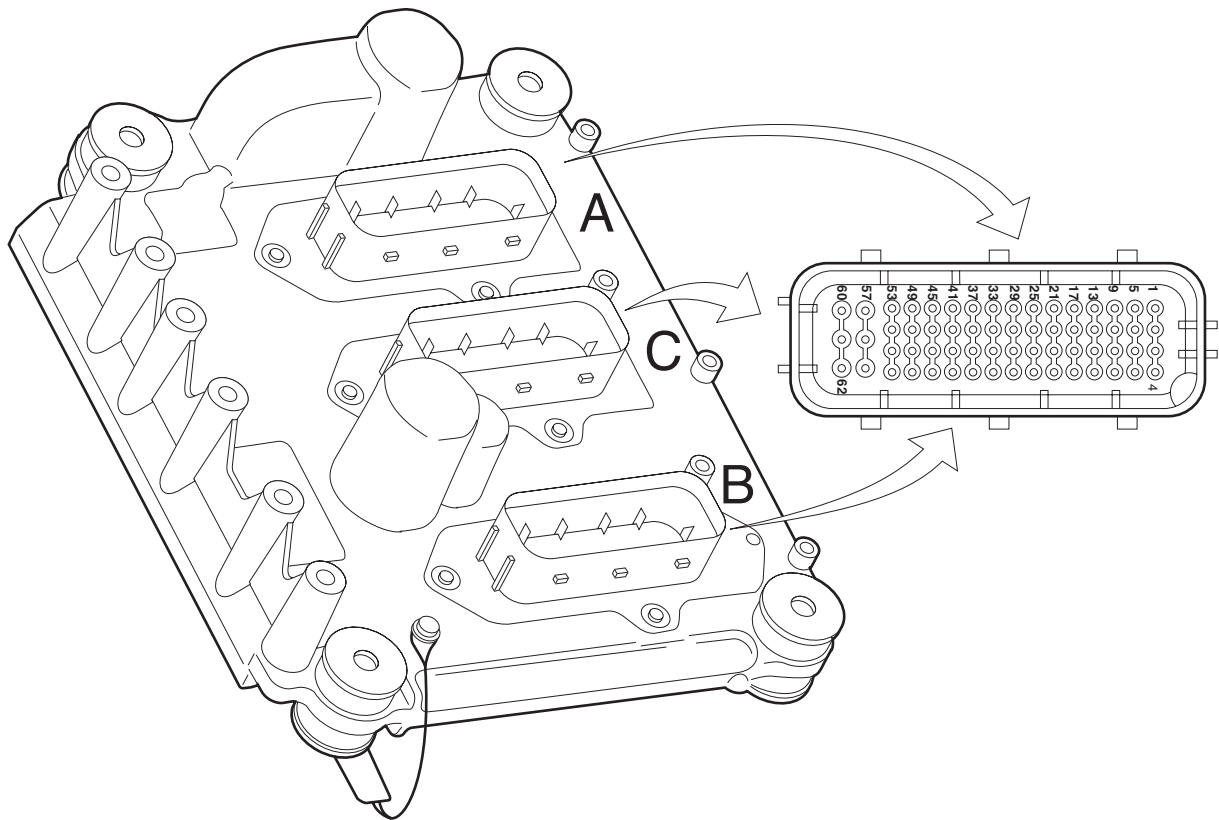

i400726

A	Electronic unit connection point				
B	Description of connection point				
C	Reading at connection point (Ubat = battery voltage)				
D	Measuring unit				
E	Explanatory notes (if applicable)				
F	Additional information available in Technical Data at "X" mark				
A	B	C	D	E	F
C29	Input signal engine oil temperature (F744)	5	V DC	Open voltage, with detached connector	X
C30	Supply voltage engine oil pressure and temperature sensor (F744)	5	V DC	Open voltage, with detached connector	
C33	Input signal engine oil pressure (F744)	0.5	V DC	Engine oil pressure 0 bar	X
		4.5	V DC	Engine oil pressure 15 bar	X
C34	Earth, engine oil pressure and temperature sensor (F744)	0	V DC		

TECHNICAL DATA

XF105 series

DMCI engine management system

Gasket

Copper ring

0

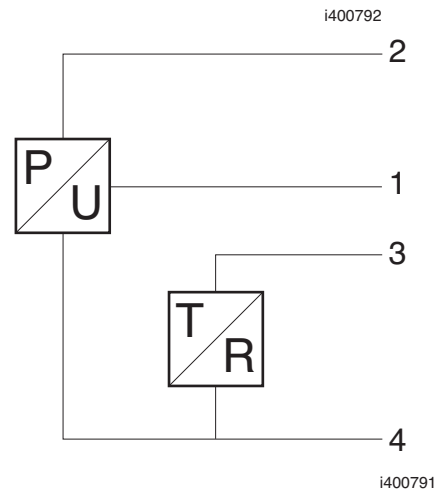
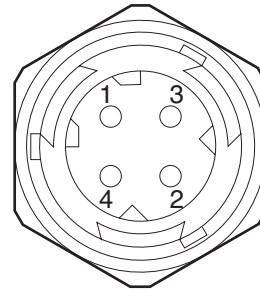
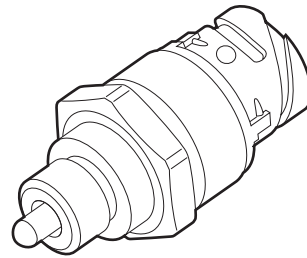

- 1. Pressure sensor supply voltage
- 2. Pressure sensor output signal
- 3. Temperature sensor output signal
- 4. Mass

Type of temperature sensor

NTC

TECHNICAL DATA

DMCI engine management system

XF105 series

0

Resistance in relation to measured temperature ⁽¹⁾

Temperature (°C)	Resistance (Ω)	
	Minimum	Maximum
- 30	24351	30653
- 20	13431	16594
- 10	7850	9095
0	4488	5372
10	2740	3236
20	1727	2010
30	1120	1295
40	746	850
50	510	574
60	355	396
70	253	279
80	185	198
90	134	145
100	100	107
110	75	81
120	57	62
130	44	48

(1) Check the resistance by measuring on connection points 3 and 4 of the sensor.

Type of pressure sensor piezo-capacitive

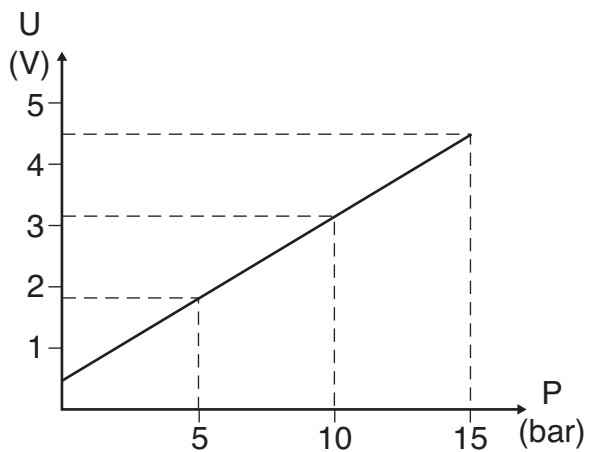

i400835

1.10 CRANKSHAFT SENSOR

0

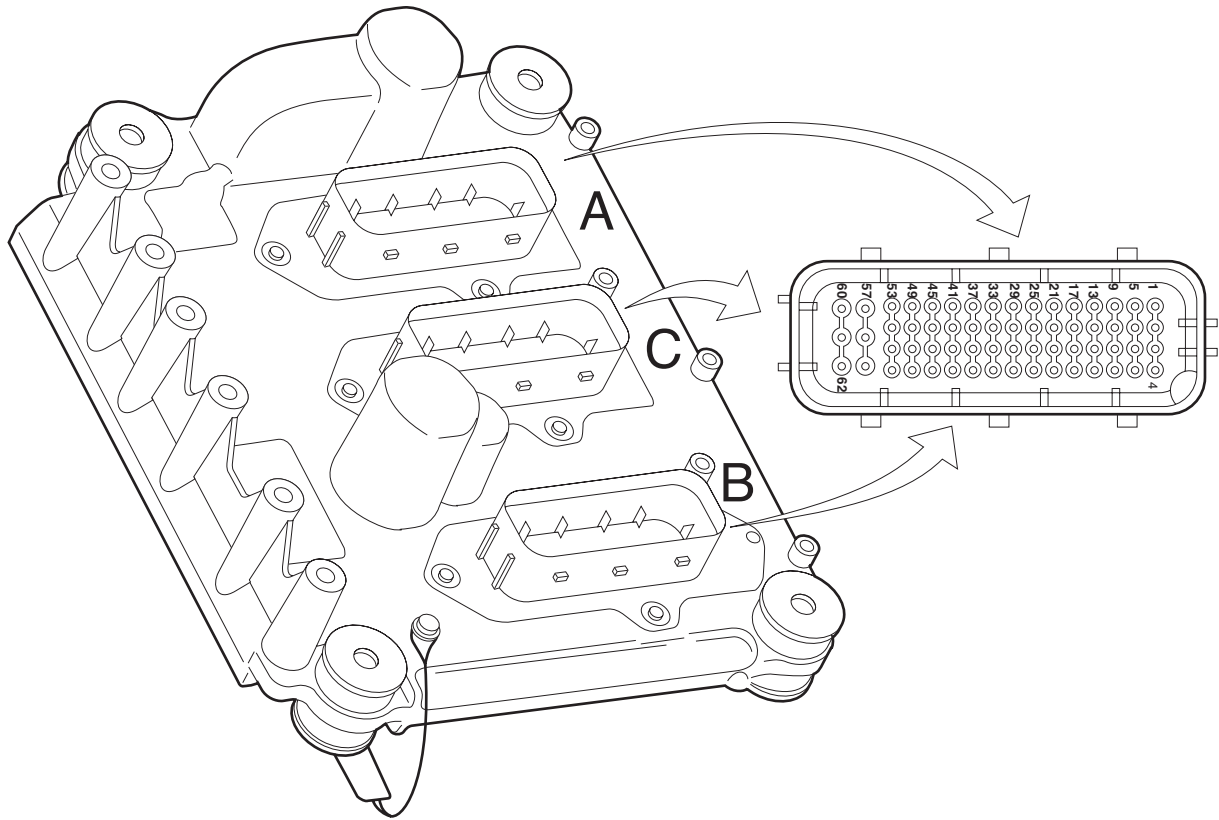

i400726

A	Electronic unit connection point				
B	Description of connection point				
C	Reading at connection point (Ubat = battery voltage)				
D	Measuring unit				
E	Explanatory notes (if applicable)				
F	Additional information available in Technical Data at "X" mark				
A	B	C	D	E	F
A49	Input signal, crankshaft sensor (F552)	-	Hz / (VAC)	Frequency depends on engine speed	X
A50	Earth, crankshaft sensor (F552)	0	V DC		
A60	Shield signal crankshaft sensor (F552)	0	V DC		

Type	Inductive
Signal version	sine-wave alternating voltage
Total number of pulses per crankshaft revolution	54
Number of cylinder detection pulses per crankshaft revolution	3
Effective voltage when starting	approx. 1.5 V ⁽¹⁾
Effective voltage when idling	approx. 4.0 V ⁽¹⁾
Effective voltage at 1200 rpm	approx. 7.0 V ⁽¹⁾
Resistance value	860Ω ± 10% at 20°C ⁽²⁾

(1) Measurements taken with multimeter in "AC voltage" position (VAC).
 (2) Measured on connection points 1 and 2 of the sensor.

TECHNICAL DATA

DMCI engine management system

XF105 series

0

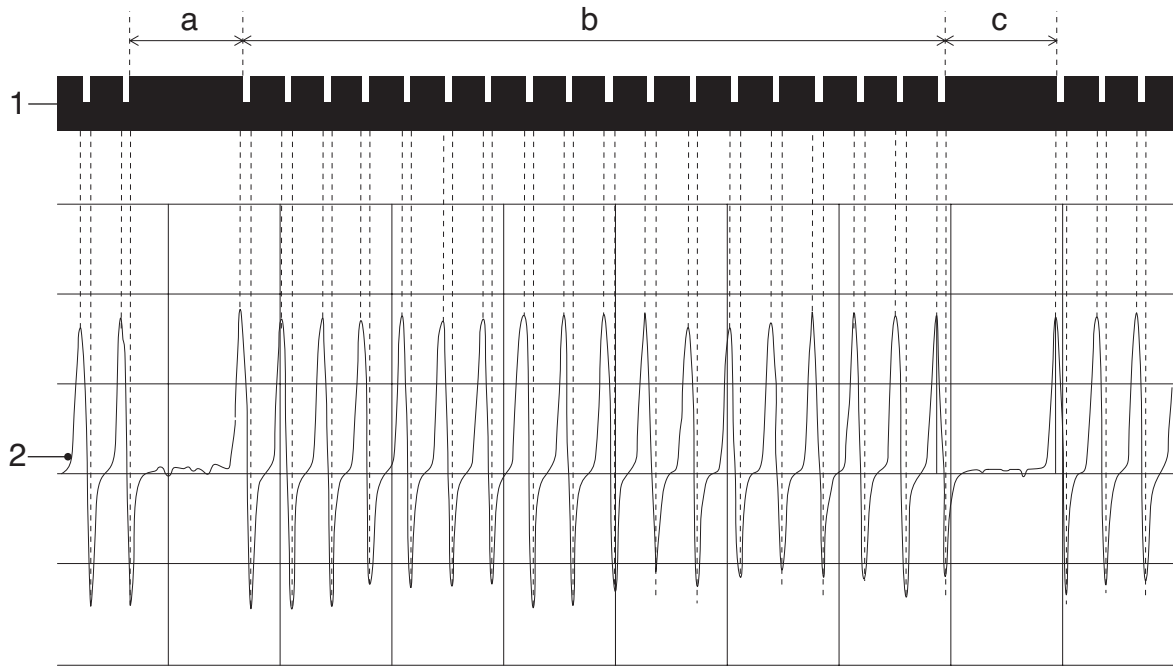

I400732

- 1. Flywheel
- a. Area with two holes missing
- b. Segment with 18 holes
- c. Area with two holes missing
- 2. Crankshaft sensor signal

1.11 CAMSHAFT SENSOR

0

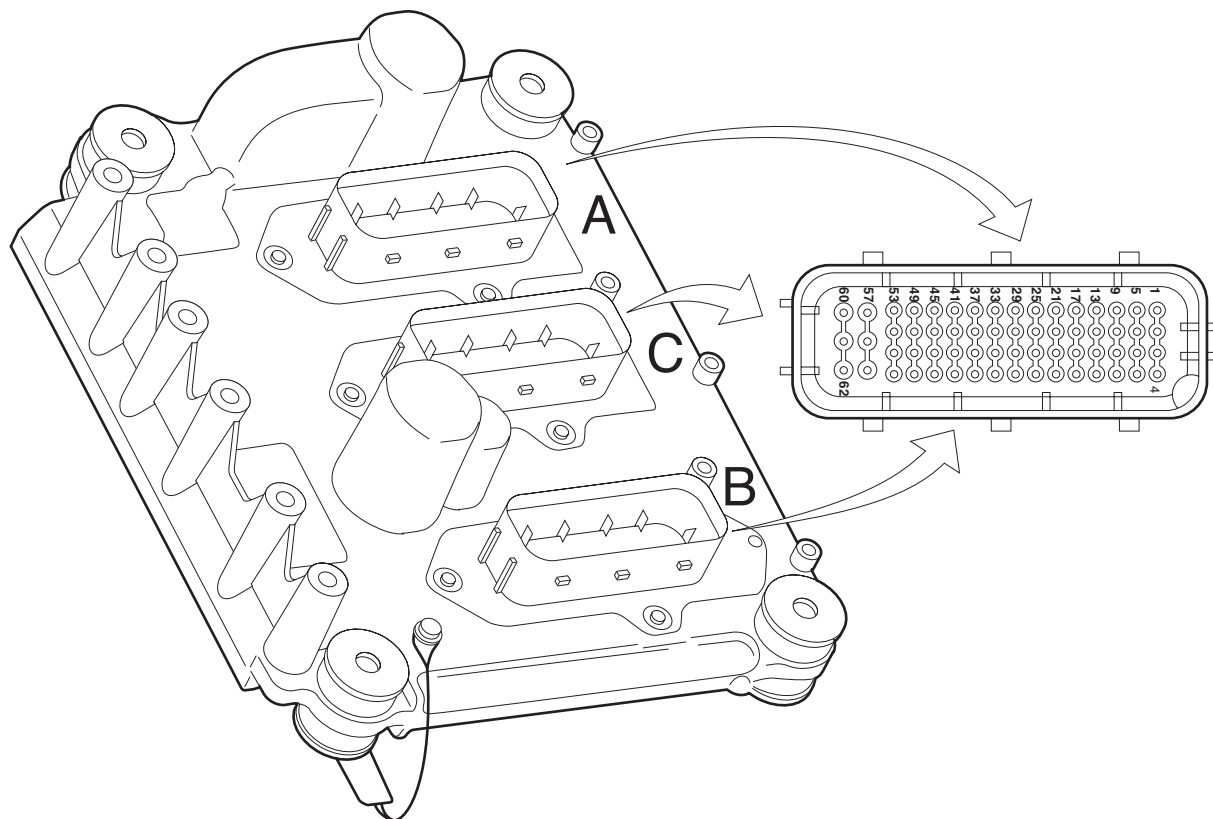

i400726

A	Electronic unit connection point				
B	Description of connection point				
C	Reading at connection point (Ubat = battery voltage)				
D	Measuring unit				
E	Explanatory notes (if applicable)				
F	Additional information available in Technical Data at "X" mark				
A	B	C	D	E	F
A53	Input signal camshaft sensor (F558)	-	Hz / (VAC)	Frequency depends on the speed	X
A54	Earth, camshaft sensor (F558)	0	V DC		
A61	Shield signal camshaft sensor (F558)	0	V DC		

Type	Inductive
Signal version	sine-wave alternating voltage
Total number of pulses for every two crankshaft revolutions	7
Effective voltage when starting	approx. 0.5 V ⁽¹⁾
Effective voltage when idling	approx. 2.0 V ⁽¹⁾
Effective voltage at 1200 rpm	approx. 4.0 V ⁽¹⁾
Resistance value	860Ω ± 10% at 20°C ⁽²⁾

(1) Measurements taken with multimeter in "AC voltage" position (VAC).

(2) Measured on connection points 1 and 2 of the sensor.

TECHNICAL DATA

DMCI engine management system

XF105 series

0

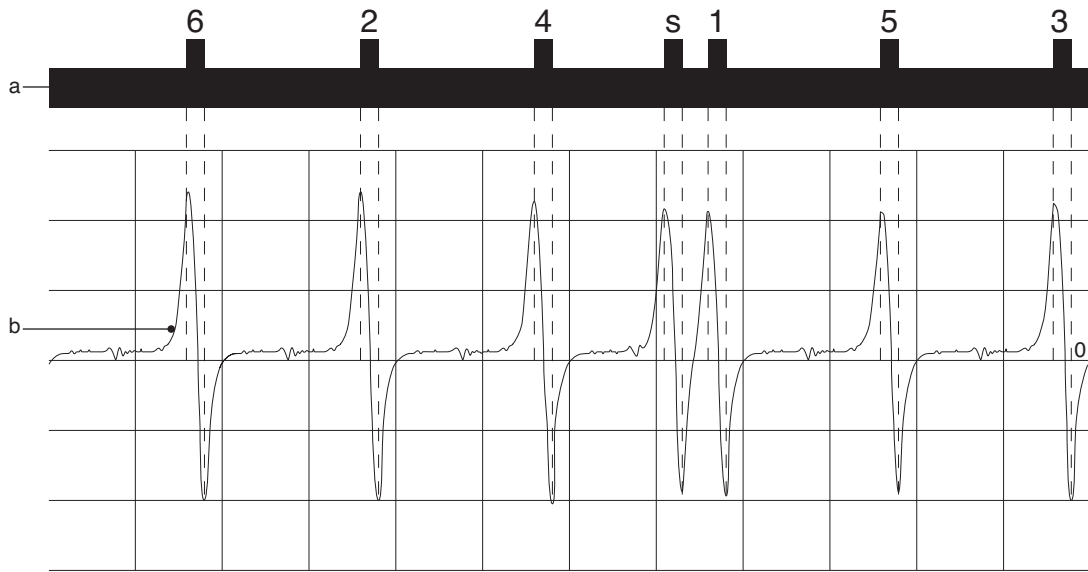

I400762

- a. Pulse wheel
- b. Camshaft sensor signal

1.12 ENGINE OIL LEVEL SENSOR

0

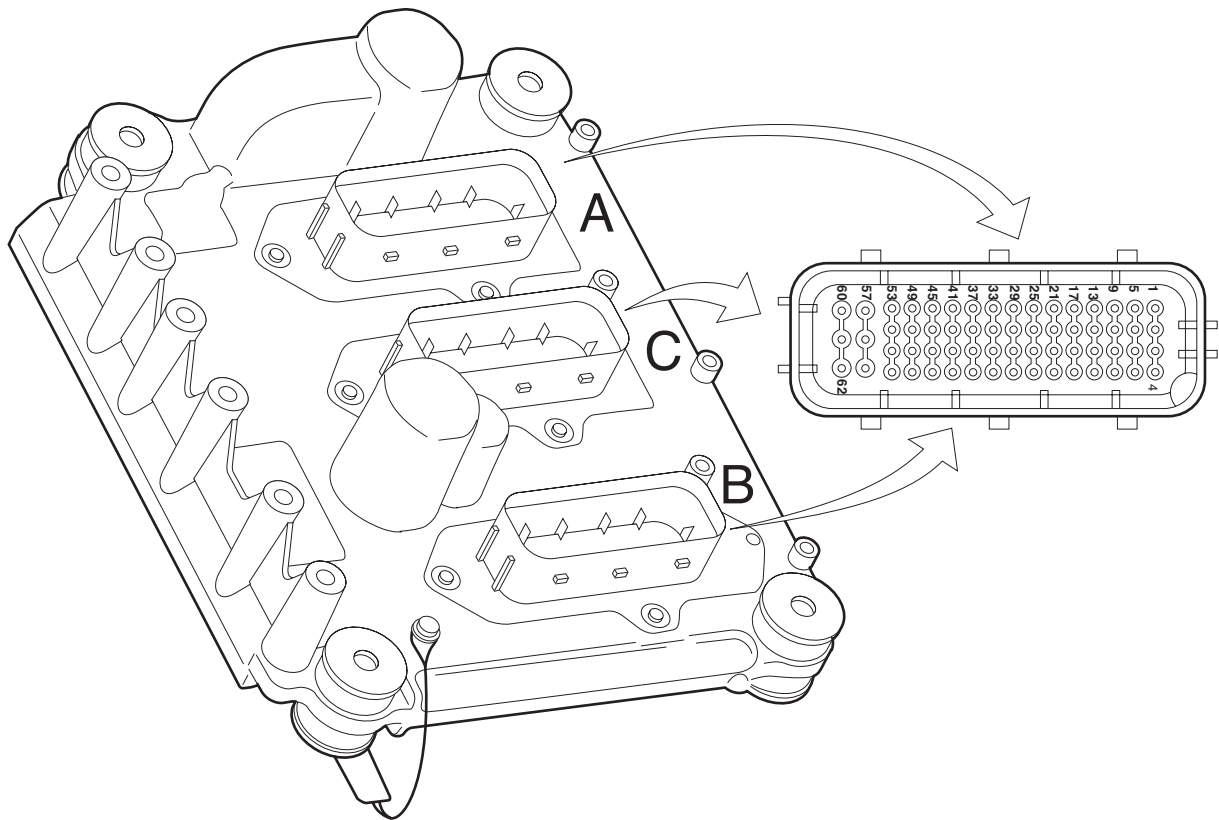

i400726

A	Electronic unit connection point				
B	Description of connection point				
C	Reading at connection point (Ubat = battery voltage)				
D	Measuring unit				
E	Explanatory notes (if applicable)				
F	Additional information available in Technical Data at "X" mark				
A	B	C	D	E	F
B13	Output and input signal oil level sensor (F673)	-	V DC	Voltage increase or decrease depending on the oil level and the oil temperature	
B14	Earth oil level sensor (F673)	0	V DC		

TECHNICAL DATA

DMCI engine management system

XF105 series

0

Supply voltage approx. 24 V
Resistance value (at 20°C) 20.5 - 23.5 Ω ⁽¹⁾

(1) During the measurement of the resistance value the current may not be more than 200mA.

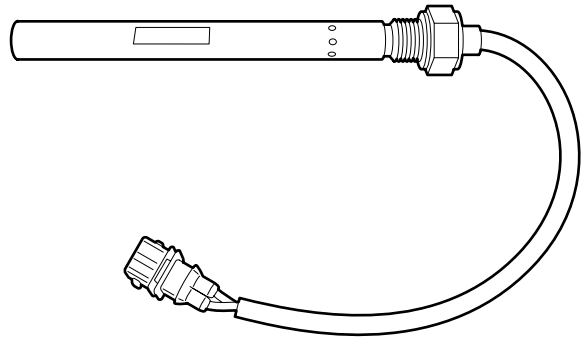

E501146

1.13 SWITCHES (MANUAL GEARBOX)

0

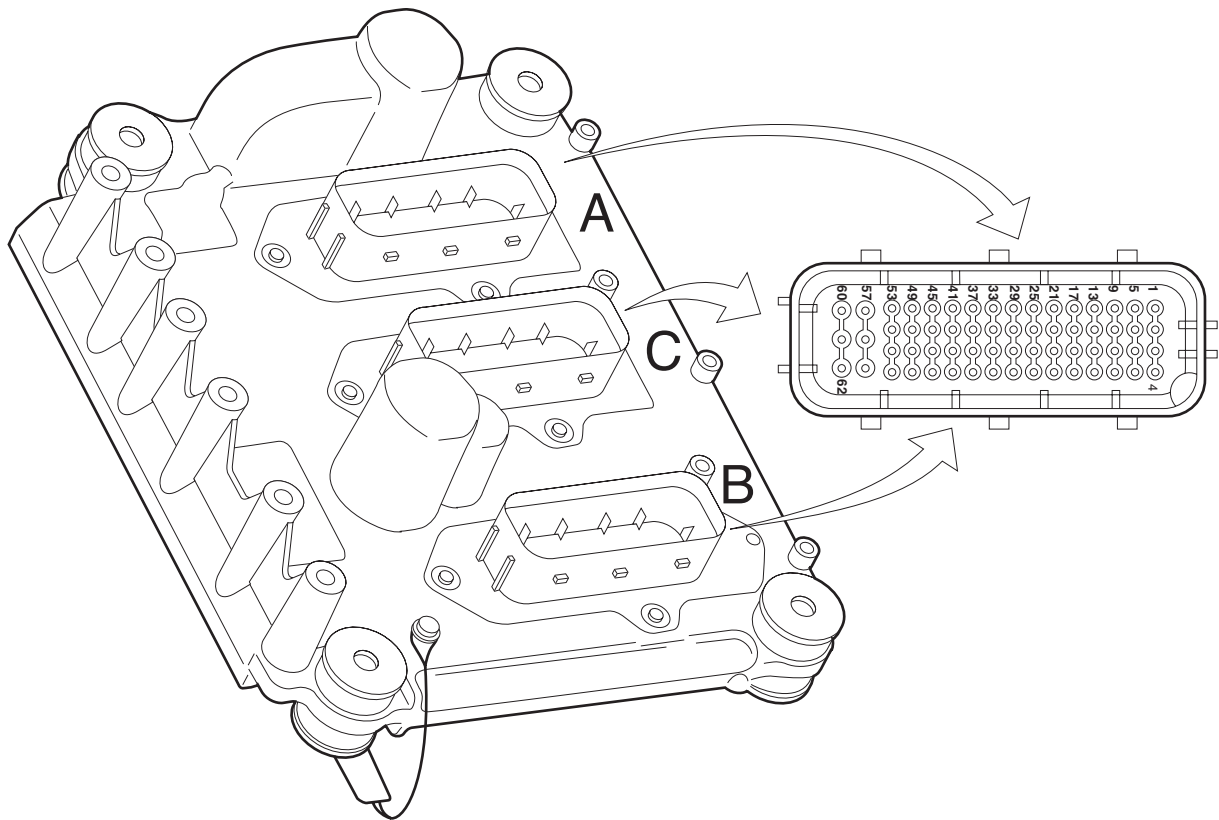

i400726

A	Electronic unit connection point				
B	Description of connection point				
C	Reading at connection point (Ubat = battery voltage)				
D	Measuring unit				
E	Explanatory notes (if applicable)				
F	Additional information available in Technical Data at "X" mark				
A	B	C	D	E	F
B36	Input signal clutch switch (E575)	0	V DC	Clutch pedal not depressed	
		Ubat	V DC	Clutch pedal fully depressed	
B40	Input signal neutral position switch (E593)	Ubat	V DC	Gearbox in neutral:	
		0	V DC	Gear box in gear	

Clutch switch

Model

Hall proximity switch

Neutral position switch

Model

Normally Open

TECHNICAL DATA

DMCI engine management system

XF105 series

0

1.14 SWITCHES (AS TRONIC)

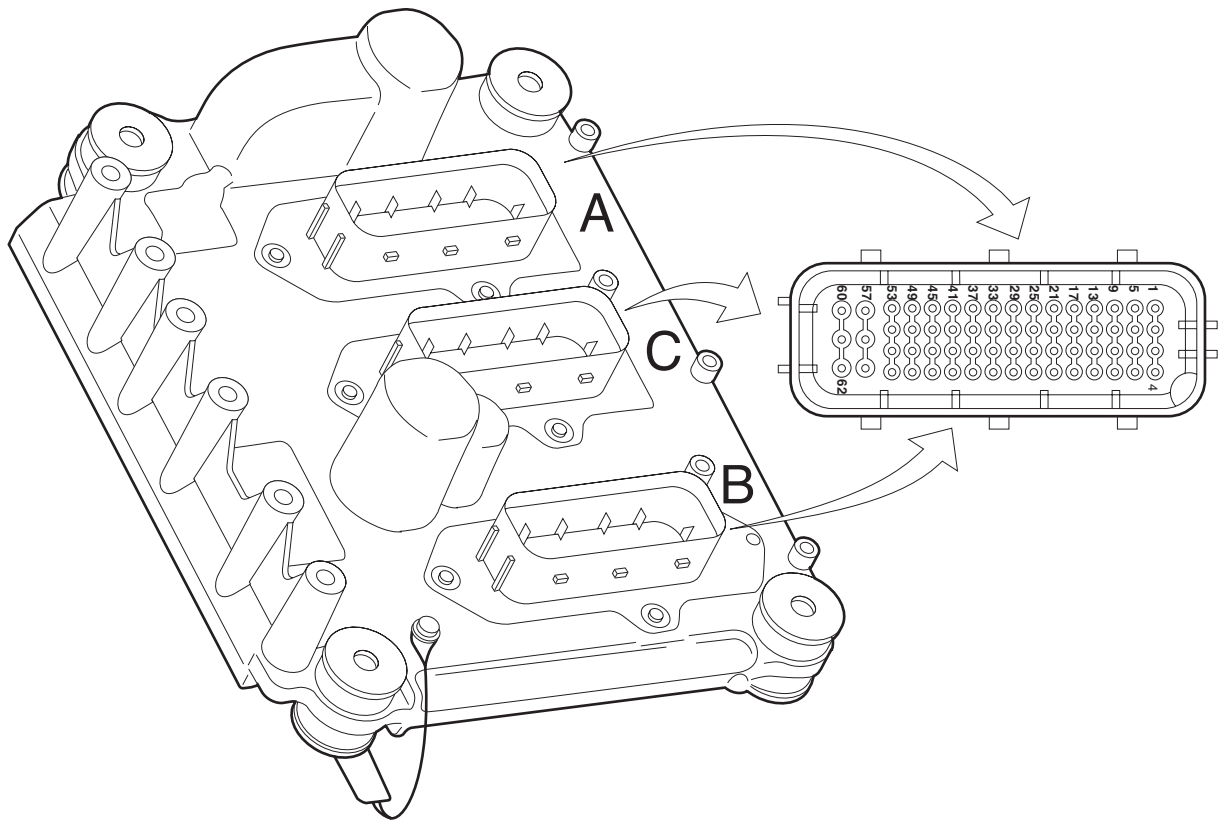

i400726

A	Electronic unit connection point				
B	Description of connection point				
C	Reading at connection point (Ubat = battery voltage)				
D	Measuring unit				
E	Explanatory notes (if applicable)				
F	Additional information available in Technical Data at "X" mark				
A	B	C	D	E	F
B40	Input signal neutral position switch (E599)	0	V DC	Gearbox in neutral	
		Ubat	V DC	Gear box in gear	

Neutral position switch

Model

Normally Closed

1.15 EXTRA BULKHEAD LEAD-THROUGH FUNCTIONS

0

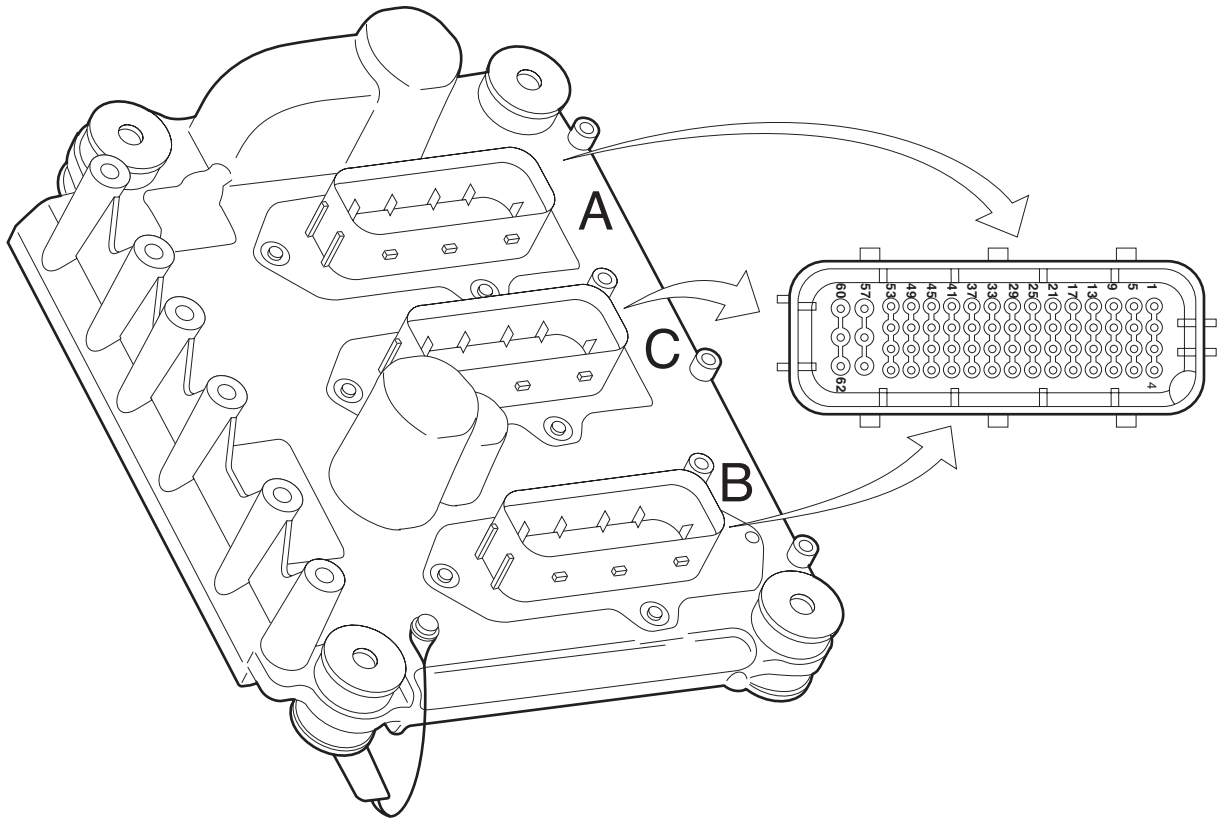

i400726

A	Electronic unit connection point				
B	Description of connection point				
C	Reading at connection point (Ubat = battery voltage)				
D	Measuring unit				
E	Explanatory notes (if applicable)				
F	Additional information available in Technical Data at "X" mark				
A	B	C	D	E	F
B1	Output signal engine speed (bulkhead lead-through connector 12C:3)	-	Hz	Frequency depends on engine speed (30 pulses per crankshaft revolution)	
B8	Input signal torque limitation 1 (bulkhead lead-through connector 12C:17)	Ubat	V DC	Only active after release. Not programmable with DAVIE XD	X
B11	Input signal torque limitation 2 (bulkhead lead-through connector 12C:20)	Ubat	V DC	Only active after release. Not programmable with DAVIE XD	X

Connection point B8	Connection point B11	Torque limiting during engine speed control
Ubat	0	Level 1: 1800 Nm
0	Ubat	Level 2: 1200 Nm
Ubat	Ubat	Level 3: 600 Nm

TECHNICAL DATA

DMCI engine management system

XF105 series

0

1.16 RED WARNING

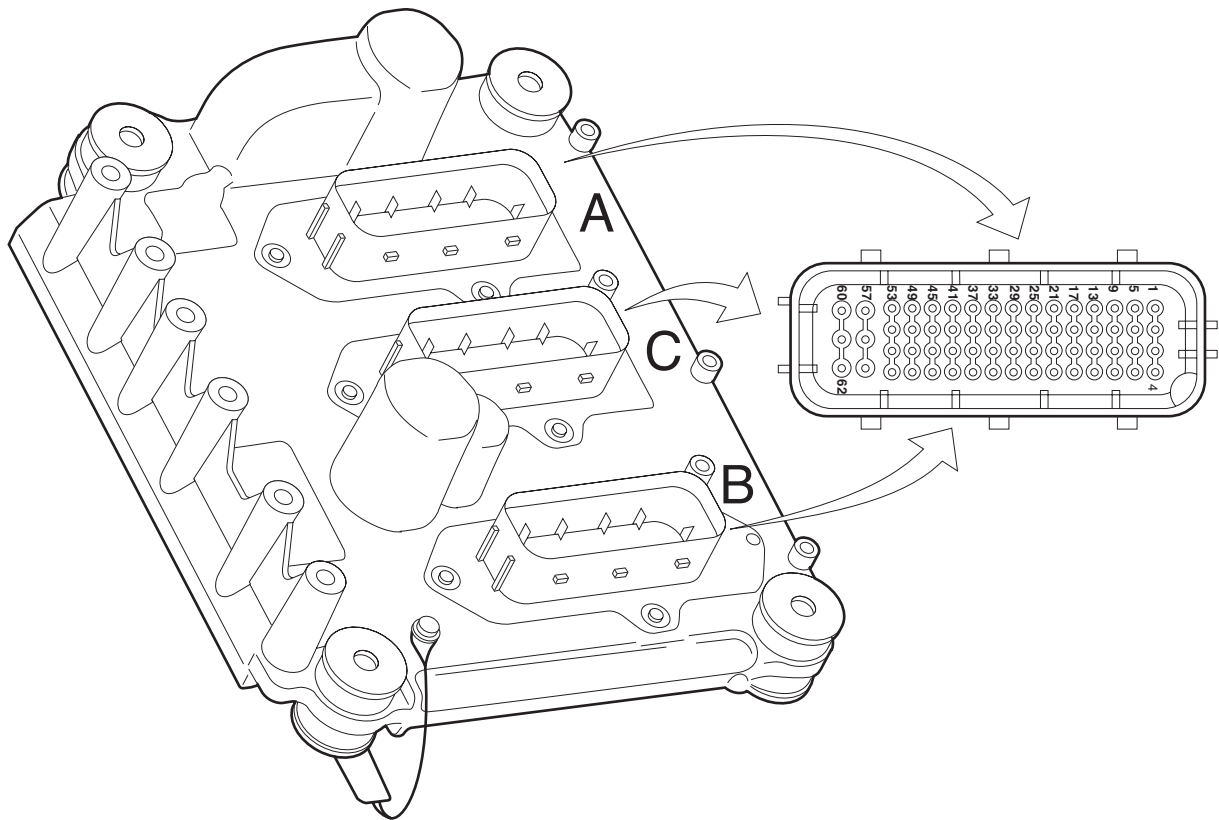

i400726

A	Electronic unit connection point				
B	Description of connection point				
C	Reading at connection point (Ubat = battery voltage)				
D	Measuring unit				
E	Explanatory notes (if applicable)				
F	Additional information available in Technical Data at "X" mark				
A	B	C	D	E	F
B22	Output signal red warning to VIC-2 (D310)	Ubat	VDC	No red warning	
		0 - 5	VDC	Red warning active (always in combination with a CAN message)	

1.17 STARTER MOTOR

0

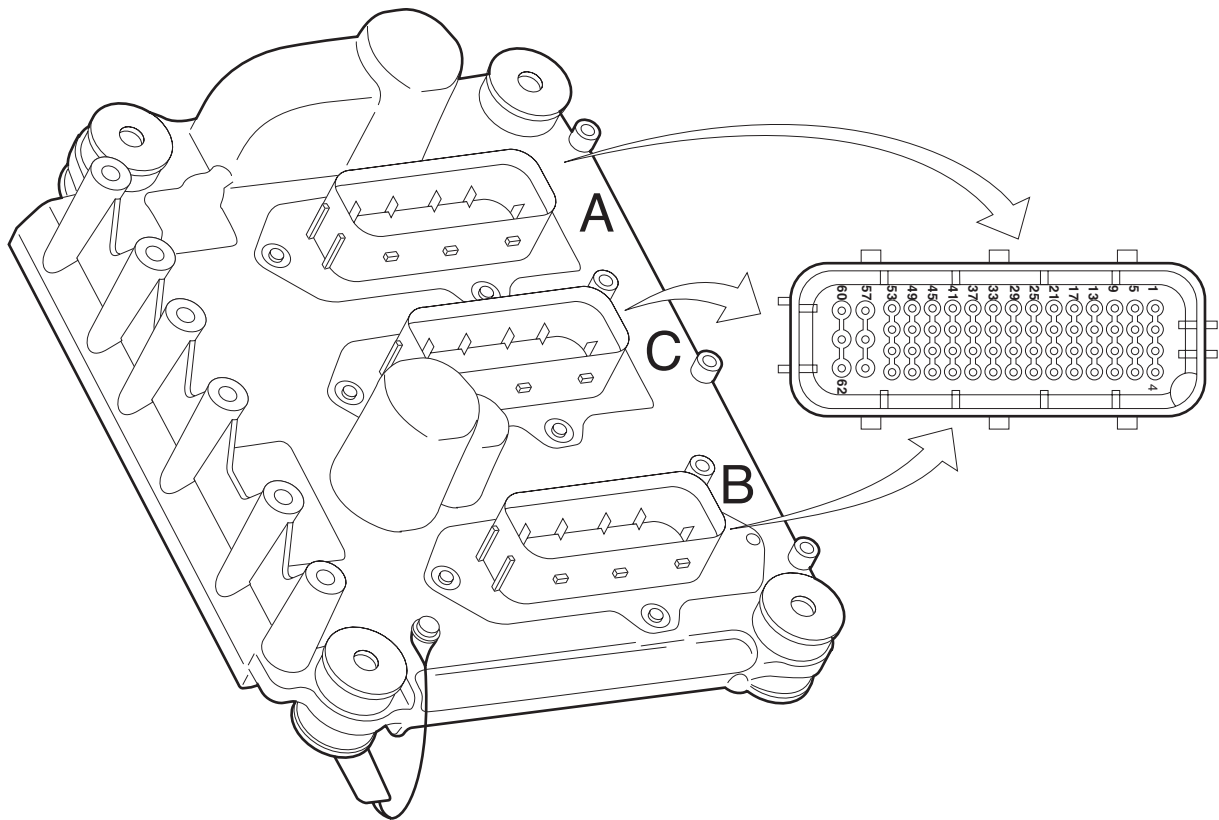

i400726

A	Electronic unit connection point				
B	Description of connection point				
C	Reading at connection point (U _{bat} = battery voltage)				
D	Measuring unit				
E	Explanatory notes (if applicable)				
F	Additional information available in Technical Data at "X" mark				
A	B	C	D	E	F
B9	Output signal earth starter motor (B010)	0	VDC	If starter motor is active	
		about 1.5	VDC	If engine is running	

TECHNICAL DATA

DMCI engine management system

XF105 series

0

1.18 GLOW COMPONENTS

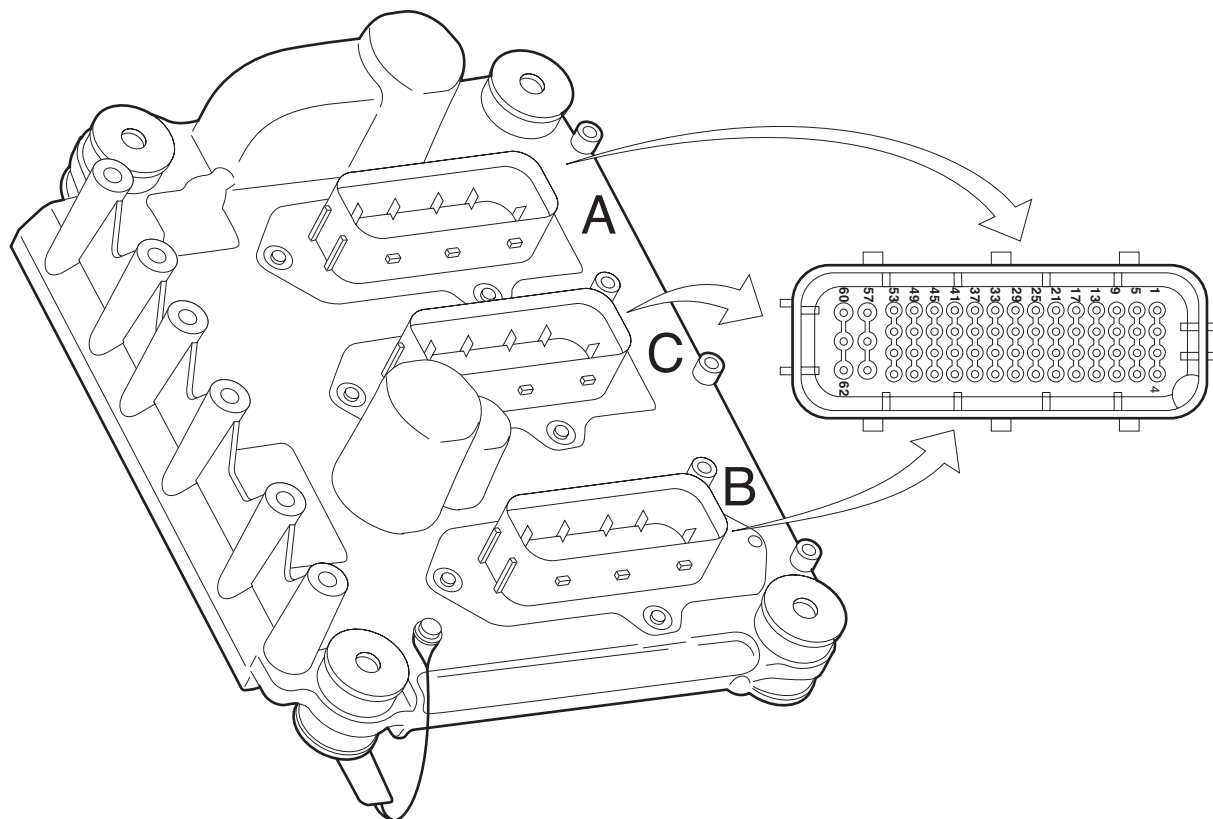

i400726

A	Electronic unit connection point				
B	Description of connection point				
C	Reading at connection point (Ubat = battery voltage)				
D	Measuring unit				
E	Explanatory notes (if applicable)				
F	Additional information available in Technical Data at "X" mark				
A	B	C	D	E	F
C32	Output signal glow relay (G014)	0	V DC	Glow relay active	
		Ubat	V DC	Glow relay not active	
C39	Input signal glow relay active (G014)	Ubat	V DC	Glow relay activated	
		0	V DC	Glow relay not active	

Glow plug relay

Supply voltage
Resistance value of coil

Ubat
21 Ω ± 10%

Glow element

Supply voltage
Rated output
Resistance value

Ubat
1.9 kW ± 10%
0.25 Ω ± 10%

1.19 WASTE GATE VALVE

0

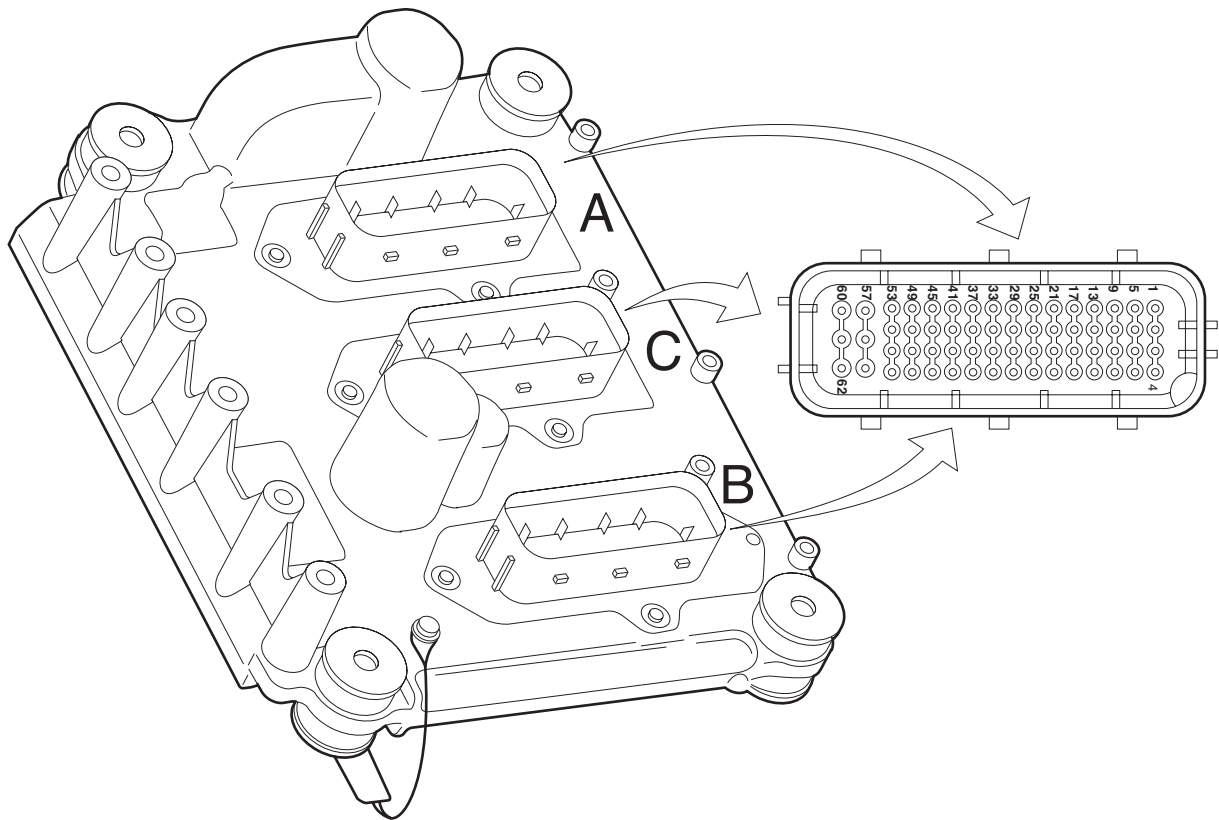

i400726

A	Electronic unit connection point				
B	Description of connection point				
C	Reading at connection point (Ubat = battery voltage)				
D	Measuring unit				
E	Explanatory notes (if applicable)				
F	Additional information available in Technical Data at "X" mark				
A	B	C	D	E	F
C8	Output signal waste gate valve (B368)	-	%	Depending on the desired boost pressure, earth-controlled duty cycle	X
C59	Earth waste gate valve (B368)	0	V DC		

TECHNICAL DATA

DMCI engine management system

XF105 series

0

Supply voltage approx. 24 V
 Air pressure approx. 10 bar
 Control signal earth-controlled duty cycle ⁽¹⁾
 Duty cycle voltage level approx. 12 V
 Frequency of duty cycle signal circa 160 Hz

10% duty cycle, earth-controlled, plus measurement pin C8 less measurement pin C59

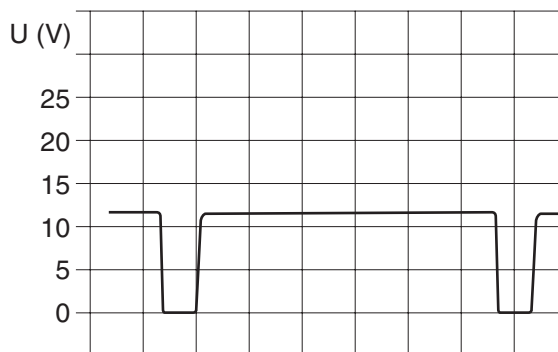

i401021

(1) Check duty cycle with the multimeter by plus measurement pin at C59 and less measurement pin at C8.

	MX375	MX410
Duty cycle (%)	Output pressure, output "2" (bar)	Output pressure, output "2" (bar)
0	0.3	0.3
10	0.3	0.3
50	1.5	2.5
90	3.0	5.0
95	3.0	5.0
100	0.3	0.3

1.20 EXHAUST BRAKE VALVE

0

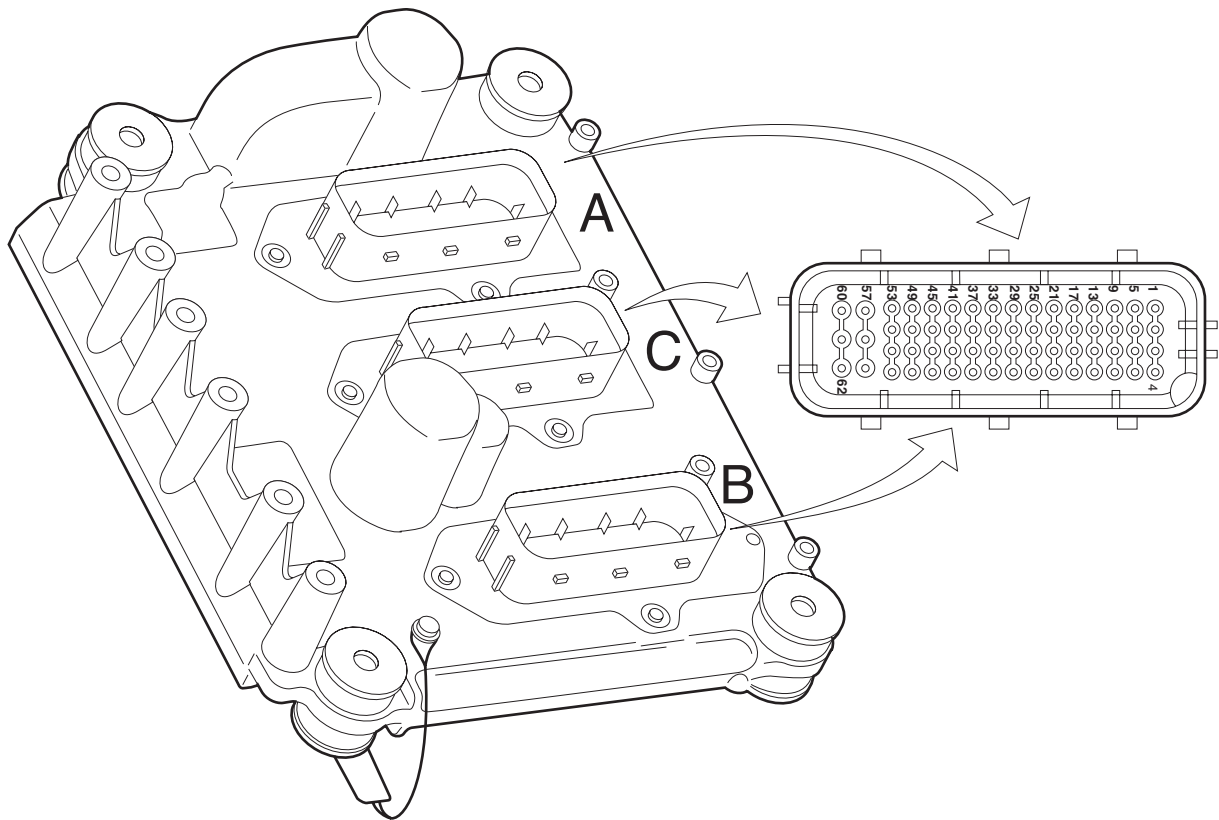

i400726

A	Electronic unit connection point				
B	Description of connection point				
C	Reading at connection point (Ubat = battery voltage)				
D	Measuring unit				
E	Explanatory notes (if applicable)				
F	Additional information available in Technical Data at "X" mark				
A	B	C	D	E	F
C28	Output signal exhaust brake valve (B192)	Ubat	VDC	Exhaust brake valve not active	
		0	VDC	Exhaust brake valve active	

Resistance value

56 Ω ± 10%

TECHNICAL DATA

DMCI engine management system

XF105 series

0

1.21 DEB SOLENOID VALVE

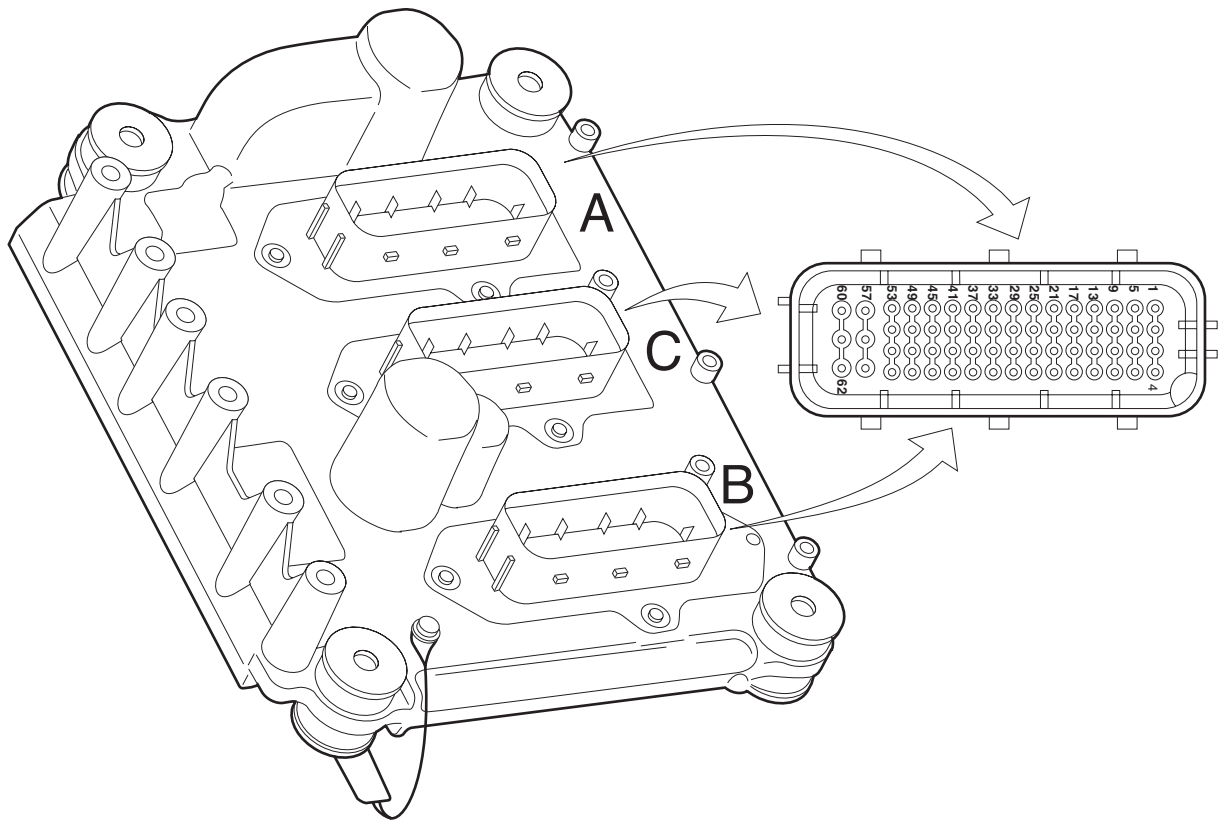

i400726

A	Electronic unit connection point				
B	Description of connection point				
C	Reading at connection point (Ubat = battery voltage)				
D	Measuring unit				
E	Explanatory notes (if applicable)				
F	Additional information available in Technical Data at "X" mark				
A	B	C	D	E	F
A35	Earth magnetic valve DEB (B411)	0	V DC		
A36	Output signal magnetic valve DEB (B411)	Ubat	V DC	DEB active	
		0	V DC	DEB not active	
A39	Earth magnetic valve DEB (B415)	0	V DC		
A40	Output signal magnetic valve DEB (B415)	Ubat	V DC	DEB active	
		0	V DC	DEB not active	
A43	Earth magnetic valve DEB (B413)	0	V DC		
A44	Output signal magnetic valve DEB (B413)	Ubat	V DC	DEB active	
		0	V DC	DEB not active	
A47	Earth magnetic valve DEB (B416)	0	V DC		

TECHNICAL DATA

XF105 series

DMCI engine management system

A	B	C	D	E	F
A48	Output signal magnetic valve DEB (B416)	Ubat	V DC	DEB active	
		0	V DC	DEB not active	
A51	Earth magnetic valve DEB (B412)	0	V DC		
A52	Output signal magnetic valve DEB (B412)	Ubat	V DC	DEB active	
		0	V DC	DEB not active	
A55	Earth magnetic valve DEB (B414)	0	V DC		
A56	Output signal magnetic valve DEB (B414)	Ubat	V DC	DEB active	
		0	V DC	DEB not active	

Resistance value

40 Ω ± 10% ⁽¹⁾

(1) Check the resistance by measuring at the valve connection points to the correct connection points of the in-line connectors.

TECHNICAL DATA

DMCI engine management system

XF105 series

0

1.22 PUMP UNIT

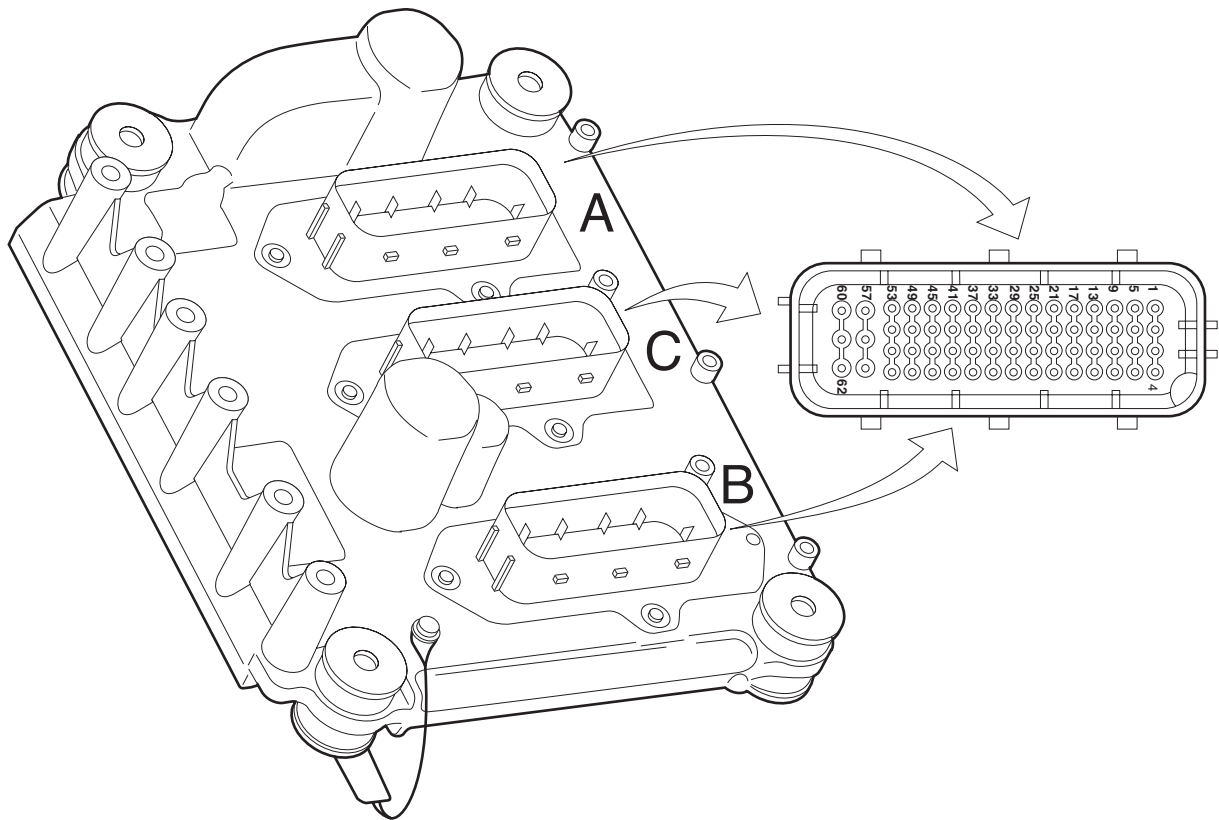

i400726

A	Electronic unit connection point				
B	Description of connection point				
C	Reading at connection point (U _{bat} = battery voltage)				
D	Measuring unit				
E	Explanatory notes (if applicable)				
F	Additional information available in Technical Data at "X" mark				
A	B	C	D	E	F
A03	Output signal high pump unit cylinder 1 (B131)	-	V DC	See scope example	X
A04	Output signal low pump unit cylinder 1 (B131)	-	V DC	See scope example	X
A07	Output signal high pump unit cylinder 3 (B133)	-	V DC	See scope example	X
A08	Output signal low pump unit cylinder 5 (B135)	-	V DC	See scope example	X
A11	Output signal high pump unit cylinder 2 (B132)	-	V DC	See scope example	X
A12	Output signal low pump unit cylinder 3 (B133)	-	V DC	See scope example	X
A15	Output signal high pump unit cylinder 5 (B135)	-	V DC	See scope example	X

TECHNICAL DATA

XF105 series

DMCI engine management system

A	B	C	D	E	F
A16	Output signal low pump unit cylinder 6 (B136)	-	V DC	See scope example	X
A19	Output signal high pump unit cylinder 6 (B136)	-	V DC	See scope example	X
A20	Output signal low pump unit cylinder 2 (B132)	-	V DC	See scope example	X
A23	Output signal low pump unit cylinder 4 (B134)	-	V DC	See scope example	X
A24	Output signal high pump unit cylinder 4 (B134)	-	V DC	See scope example	X

Pick-up voltage approx. 50 V
 Withstand voltage approx. 24 V

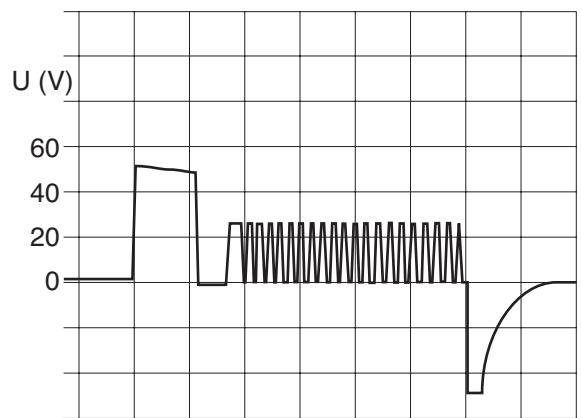

i400845

Solenoid valve resistance value ⁽¹⁾

-40°C	1.1 Ω
20°C	1.6 Ω
120°C	2.4 Ω

(1) Check the resistance by measuring on the connection points of the pump unit.

TECHNICAL DATA

DMCI engine management system

XF105 series

0

1.23 INJECTOR

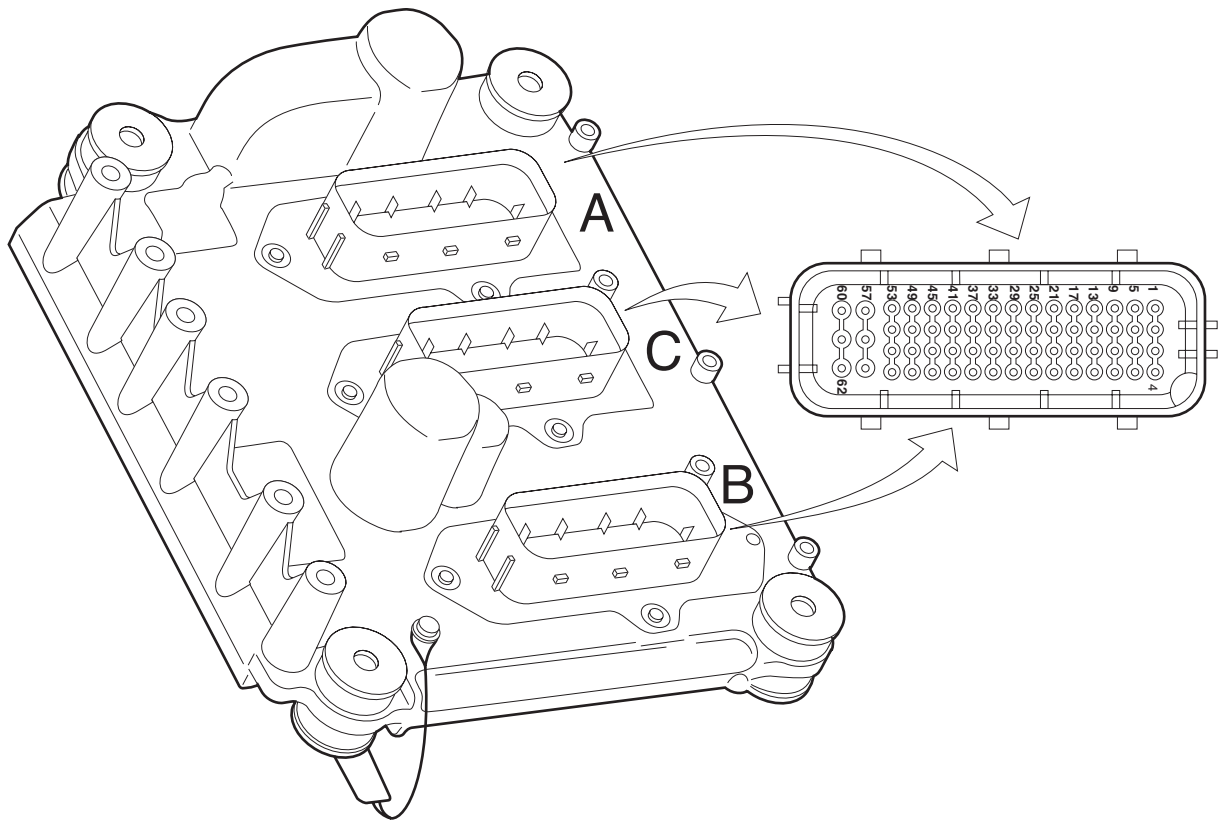

i400726

A	Electronic unit connection point				
B	Description of connection point				
C	Reading at connection point (Ubat = battery voltage)				
D	Measuring unit				
E	Explanatory notes (if applicable)				
F	Additional information available in Technical Data at "X" mark				
A	B	C	D	E	F
A01	Output signal low injector cylinder 1 (B421)		V DC	See scope example	
A02	Output signal high injector cylinder 1 (B421)		V DC	See scope example	
A05	Output signal low injector cylinder 5 (B425)		V DC	See scope example	
A06	Output signal high injector cylinder 3 (B423)		V DC	See scope example	
A09	Output signal low injector cylinder 3 (B423)		V DC	See scope example	
A10	Output signal high injector cylinder 2 (B422)		V DC	See scope example	
A13	Output signal low injector cylinder 6 (B426)		V DC	See scope example	

TECHNICAL DATA

XF105 series

DMCI engine management system

A	B	C	D	E	F
A14	Output signal high injector cylinder 5 (B425)		V DC	See scope example	
A17	Output signal low injector cylinder 2 (B422)		V DC	See scope example	
A18	Output signal high injector cylinder 6 (B426)		V DC	See scope example	
A21	Output signal low injector cylinder 4 (B424)		V DC	See scope example	
A22	Output signal high injector cylinder 4 (B424)		V DC	See scope example	

Pick-up voltage approx. 50 V
 Withstand voltage approx. 24 V

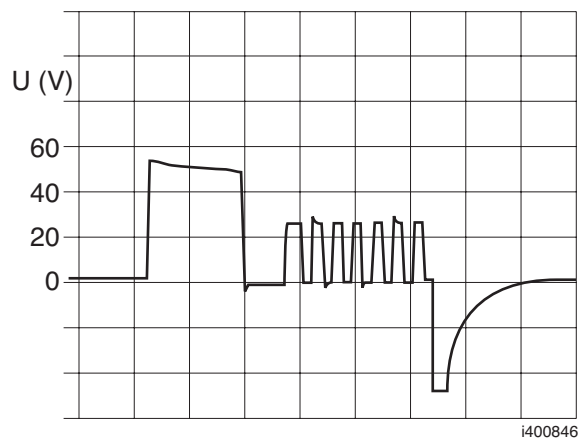

Solenoid valve resistance value ⁽¹⁾

-40°C	1.1 Ω
20°C	1.6 Ω
120°C	2.4 Ω

(1) Check the resistance by measuring at the injector connection points to the correct connection points of the in-line connectors.

TECHNICAL DATA

DMCI engine management system

XF105 series

0

1.24 ELECTRONICALLY CONTROLLED FAN CLUTCH

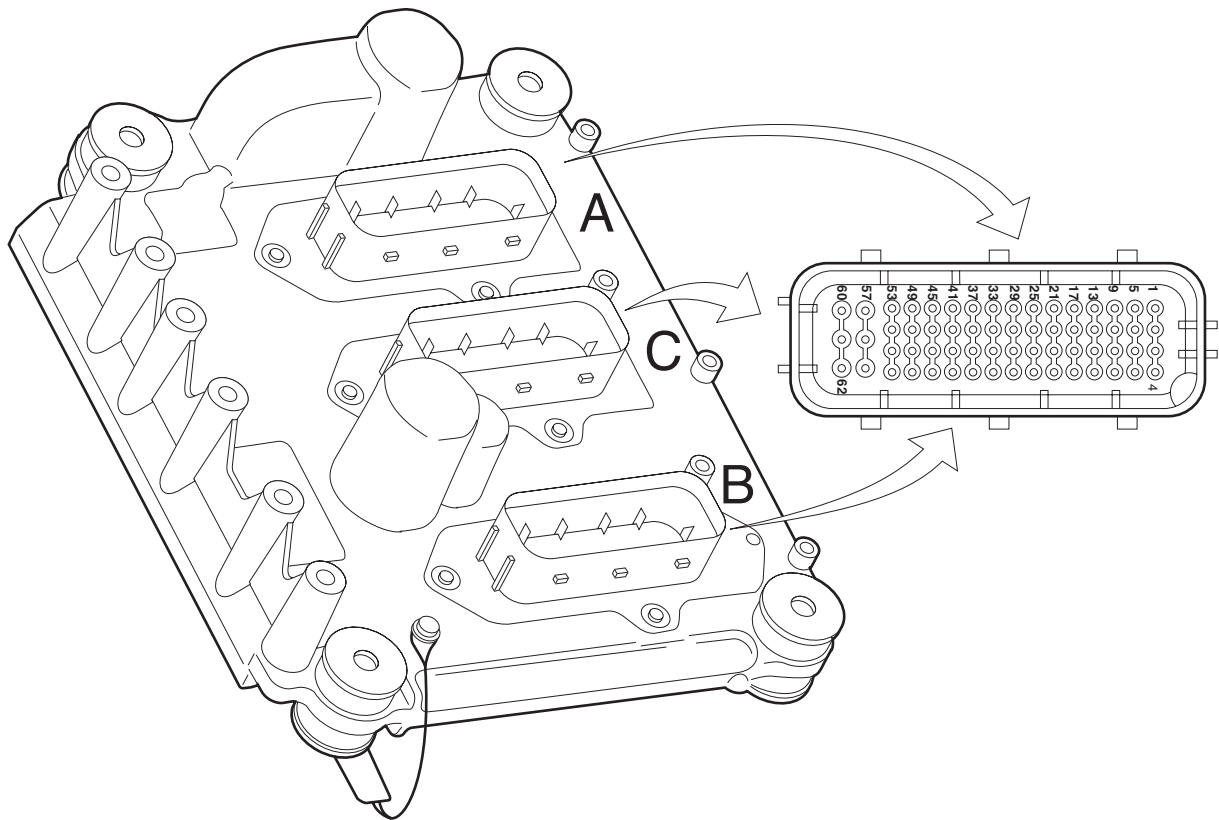

i400726

A	Electronic unit connection point				
B	Description of connection point				
C	Reading at connection point (Ubat = battery voltage)				
D	Measuring unit				
E	Explanatory notes (if applicable)				
F	Additional information available in Technical Data at "X" mark				
A	B	C	D	E	F
C16	Output signal fan clutch control	-	%	Earth-controlled duty cycle	X
		Ubat	VDC	Ignition on	
C31	Fan clutch speed sensor earth	0	VDC		
C35	Fan clutch speed sensor power supply	5	VDC		
C36	Fan clutch speed sensor input signal	-	Hz	Square wave signal	X

TECHNICAL DATA

XF105 series

DMCI engine management system

0

Type of speed sensor Hall
 Speed sensor output signal Square-wave signal 5 V
 Frequency at 1000 rpm fan speed 100 Hz
 Pulses per fan revolution 6

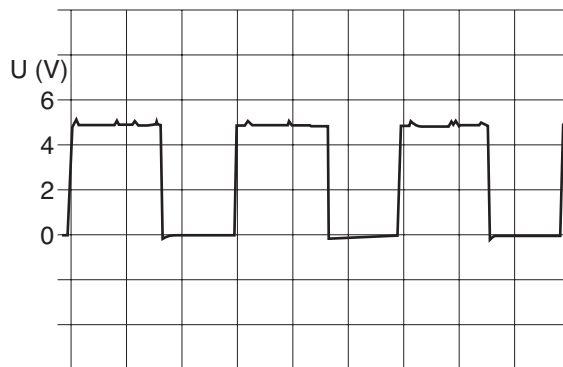

i400848

Fan clutch control earth-controlled duty cycle (0 - 100%)
 Duty cycle voltage level 24 V
 Frequency of duty cycle signal 2 Hz
 Duty cycle high ⁽¹⁾ Decreasing fan speed
 Duty cycle low ⁽¹⁾ Increasing fan speed

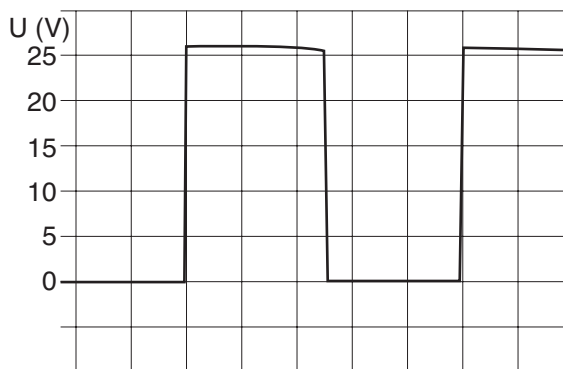

i400847

(1) Measured with plus probe on pin B60 and minus probe on pin C16

1. Fan speed sensor output signal
2. Fan speed sensor earth
3. Fan clutch control signal
4. Fan clutch supply voltage 24V
5. Fan speed sensor supply voltage 5V

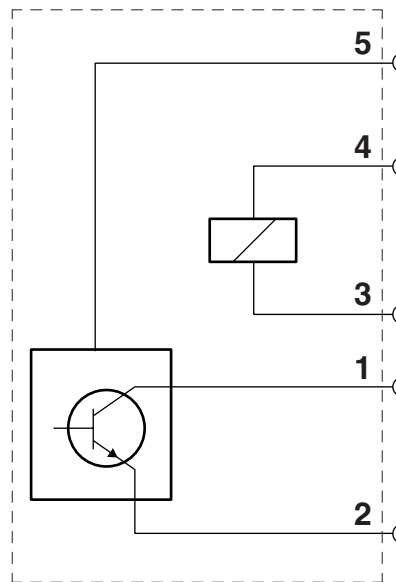

i 400456

TECHNICAL DATA

DMCI engine management system

XF105 series

0

DMCI ENGINE MANAGEMENT SYSTEM

XF105 series

Contents

CONTENTS

	Page	Date
1. SYSTEM DESCRIPTION	1-1	200528
1.1 Introduction	1-1	200528
1.2 Electrical system	1-2	200528
1.3 System description of fuel system	1-5	200528
2. DESCRIPTION OF COMPONENTS	2-1	200528
2.1 DMCI electronic unit	2-1	200528
2.2 Accelerator pedal sensor	2-2	200528
2.3 Coolant temperature sensor	2-4	200528
2.4 2 nd coolant temperature sensor	2-4	200528
2.5 Inlet air boost pressure and temperature sensor	2-5	200528
2.6 Fuel pressure and temperature sensor	2-7	200528
2.7 Engine oil pressure and temperature sensor	2-8	200528
2.8 Crankshaft sensor	2-9	200528
2.9 Camshaft sensor	2-12	200528
2.10 Waste gate valve	2-15	200528
2.11 Pump unit	2-17	200528
2.12 Injector	2-23	200528
2.13 Electronically controlled fan clutch	2-27	200528
3. CONTROL FUNCTIONS	3-1	200528
3.1 System status	3-1	200528
3.2 CAN controls	3-3	200528
3.3 Pre-glowing and after-glowing	3-5	200528
3.4 Immobiliser and start interruption	3-7	200528
3.5 Cylinder detection and synchronisation	3-9	200528
3.6 Fuel injection when starting	3-14	200528
3.7 Injection timing control	3-15	200528
3.8 Idling control	3-16	200528
3.9 Turbocharger pressure control	3-17	200528
3.10 Smoke limitation	3-19	200528
3.11 Engine brake control	3-20	200528
3.12 Fan clutch control	3-24	200528
3.13 Engine protection functions	3-27	200528
3.14 Vehicle speed limiting functions	3-32	200528
3.15 Cruise control	3-34	200528
3.16 Downhill Speed Control	3-37	200528
3.17 Engine speed control	3-40	200528
4. DIAGRAMS	4-1	200528
4.1 Key to block diagram DMCI	4-1	200528
4.2 Block diagram DMCI	4-3	200528



DMCI ENGINE MANAGEMENT SYSTEM

Contents

XF105 series

1

1. SYSTEM DESCRIPTION

1.1 INTRODUCTION

The design, functions and controls of the "DMCI" engine management system are described in this systems manual.

"DMCI" stands for DAF Multi Controlled Injection. Fuel injection is controlled by an electronically controlled pump unit and an electronically controlled injector.

The pump unit is responsible for the fuel supply to the injector. Injection timing is determined by the injector. Injection quantity is determined by the pump unit and injector in combination.

Of course, the DMCI electronic unit requires various sensors to control these two components correctly in order to determine the injection timing and the correct quantity of fuel to be injected.

DMCI ENGINE MANAGEMENT SYSTEM

System description

XF105 series

1

1.2 ELECTRICAL SYSTEM

The electronic unit is the central control device of the DMCI engine management system. The functions can be split into engine functions and vehicle functions.

Note:

Functions may be optional or may depend on the vehicle configuration.

Engine functions:

- system status
- CAN controls
- pre-glowing and after-glowing
- control of fuel supply
- cylinder detection and synchronisation
- fuel injection when starting
- injection timing control
- idling control
- turbocharger pressure control
- smoke limitation
- full-load limiting and engine protection functions
- engine brake control
- fan clutch control

Vehicle functions:

- Cruise control
- downhill speed control
- vehicle speed limiting prescribed by law
- variable vehicle speed limiting
- vehicle speed limiting for special applications
- engine speed control
- CAN controls

DMCI ENGINE MANAGEMENT SYSTEM

XF105 series

System description

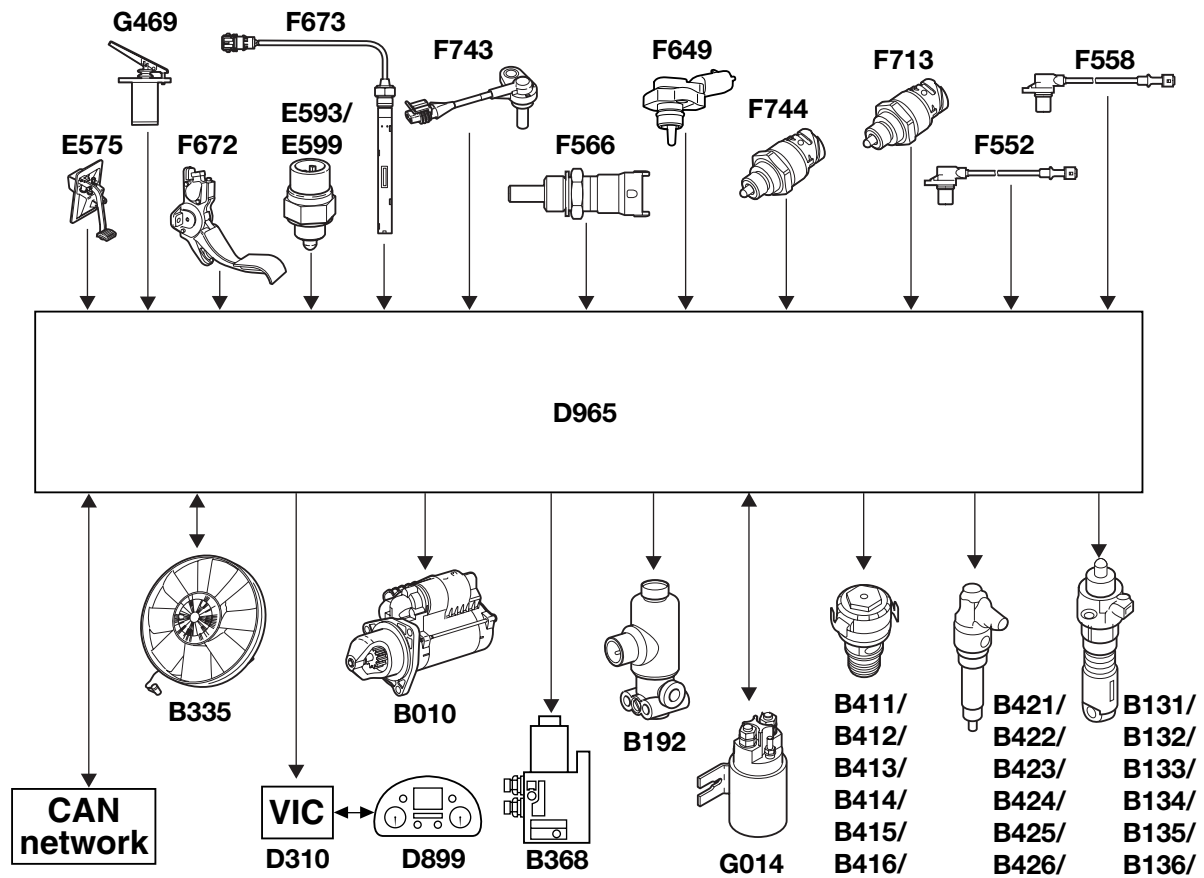

i400991

The DMCI electronic unit needs different input signals to control engine and vehicle functions and various components are activated by output signals.

Input signals

The most important input signals are:

- clutch proximity switch (E575)
- service brake (G469)
- accelerator pedal sensor (F672)
- neutral position switch (F593/F599)
- oil level sensor (F673)
- 2nd coolant temperature sensor (F743)
- coolant temperature sensor (F566)
- air inlet boost pressure and temperature sensor (F649)
- engine oil pressure and temperature sensor (F744)
- fuel pressure and temperature sensor (F713)
- crankshaft sensor (F552)
- camshaft sensor (F558)
- electronically controlled fan clutch (B335)
- glow relay (G014)

DMCI ENGINE MANAGEMENT SYSTEM

System description

XF105 series

Output signals

After processing of the input signals, output signals control the following components:

- electronically controlled fan clutch (B335)
- red warning VIC-2 (D310)
- waste gate valve (B368)
- starter motor (B010)
- exhaust brake valve (B192)
- DEB solenoid valves (B411 to B416)
- glow relay (G014)
- pump units (B131 to B136)
- injectors (B421 to B426)

The DMCI communicates with the various other electronic systems in the vehicle via the CAN network.

DAVIE XD is used to diagnose faults on the DMCI.

1

DMCI ENGINE MANAGEMENT SYSTEM

XF105 series

System description

1.3 SYSTEM DESCRIPTION OF FUEL SYSTEM

Fuel system

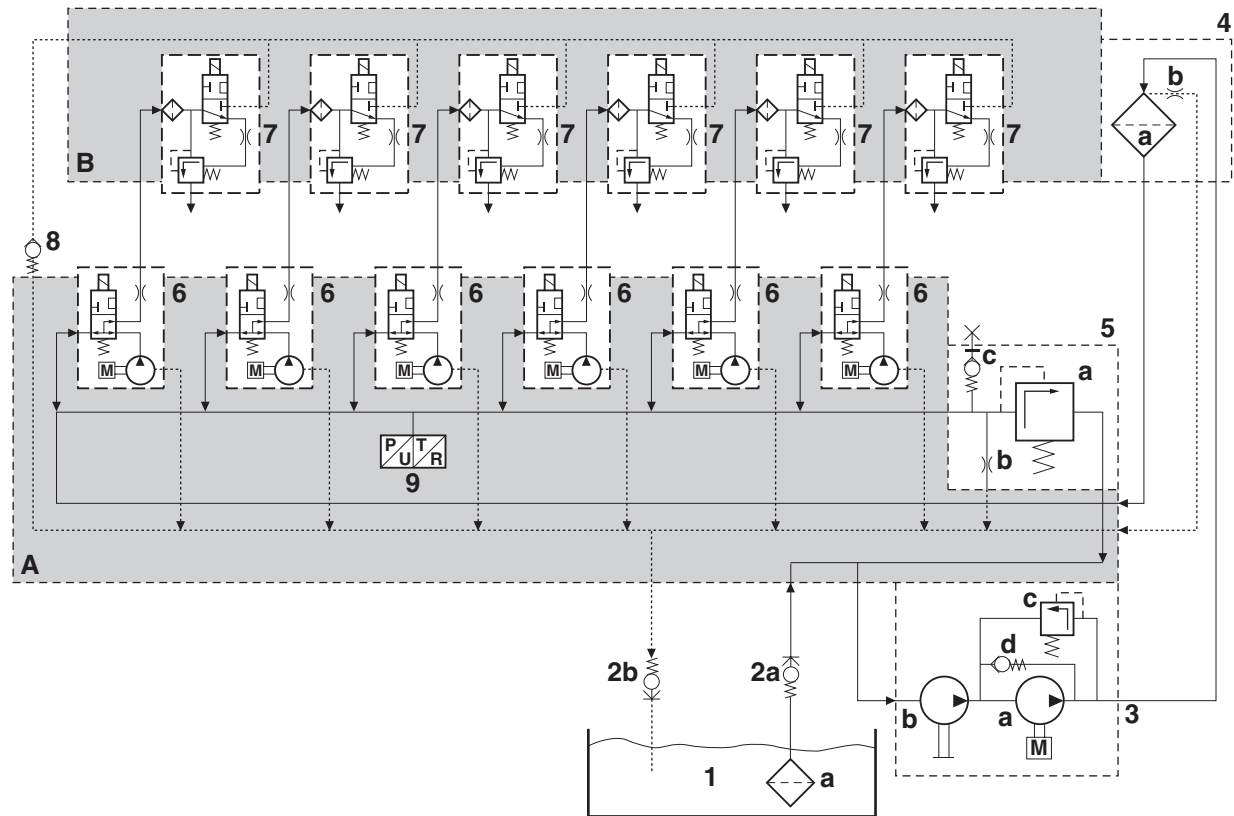

i400749

- | | | | |
|----|-------------------------|----|--------------------------------------|
| A | Cylinder block | 4 | Fuel filter |
| B | Cylinder head | 4a | Filter element |
| 1 | Fuel tank | 4b | Bleed restriction |
| 1a | Fuel-tank coarse filter | 5 | Fuel pressure control valve |
| 2a | Shut-off valve, supply | 5a | Pressure control flap |
| 2b | Shut-off valve, return | 5b | Throttle bleed/idling speed |
| 3 | Fuel pump | 5c | Fuel pressure measuring point |
| 3a | Lift pump | 6 | Pump units |
| 3b | Primer pump | 7 | Injectors |
| 3c | Pressure release valve | 8 | Non-return valve |
| 3d | Circulation valve | 9 | Fuel pressure and temperature sensor |

The fuel lift pump (3a) draws fuel out of the fuel tank (1) via a shut-off valve (2a) in the supply pipe. The fuel goes to the fuel pump (3) via the cylinder block (A). The fuel lift pump (3a) pumps the fuel via the fuel filter (4) to the fuel gallery in the cylinder block (A). The pressure in the fuel

DMCI ENGINE MANAGEMENT SYSTEM

System description

XF105 series

1

gallery is controlled by the pressure control flap (5a) in the fuel pressure control valve (5). The valve (5a) opens at a specific pressure and the fuel is led back to the intake side of the fuel pump (3).

There is a calibrated opening (5b) in the fuel pressure control valve (5) that ensures cooling of the fuel system, by means of fuel flow-back, at low engine speeds and in situations where fuel is not injected (e.g. DEB in use). This calibrated opening (5b) also ensures that pressure in the fuel gallery is stable at low speeds and therefore that pump pressures are low.

There is a test connection (5c) on the fuel pressure control valve (5) for measuring the fuel gallery pressure.

The fuel flows to the pump units (6) from the fuel gallery. If the solenoid valve in the pump unit is not activated, the pump unit pumps the fuel back into the fuel gallery. If the solenoid valve in the pump unit is activated, the fuel is pumped at high pressure to the injectors (7) via the fuel injection pipes.

If the solenoid valve in the injector is activated, an injection takes place.

The lubricating and leak-off fuel from the pump unit plunger is discharged to the return gallery in the cylinder block via a bore. The return and leak-off fuel from the injectors flows to the return gallery in the cylinder block via a bore in the cylinder head and the fuel return pipe with non-return valve (8).

The return fuel flows back to the tank via a shut-off valve (2b).

The shut-off valves (2a and 2b) are opened when the fuel pipes are connected. When the fuel pipes between engine and chassis are disconnected, the valves close the opening to the cylinder block.

DMCI ENGINE MANAGEMENT SYSTEM

XF105 series

System description

1

Fuel filter

There is a coarse filter (1a) in the fuel tank (1), which prevents any larger impurities from the bottom of the fuel tank getting into the fuel lift pump. From the fuel lift pump, fuel is pumped to the fuel gallery through the fuel fine filter (4). The fuel filter is self-bleeding. There is a throttle (3b) at the highest point in the fuel fine filter (4) through which air in the system is discharged to the fuel tank.

Basic function of injection

The pump unit and injector work in tandem to bring about fuel injection. A complete fuel injection cycle is described in the following steps.

Filling

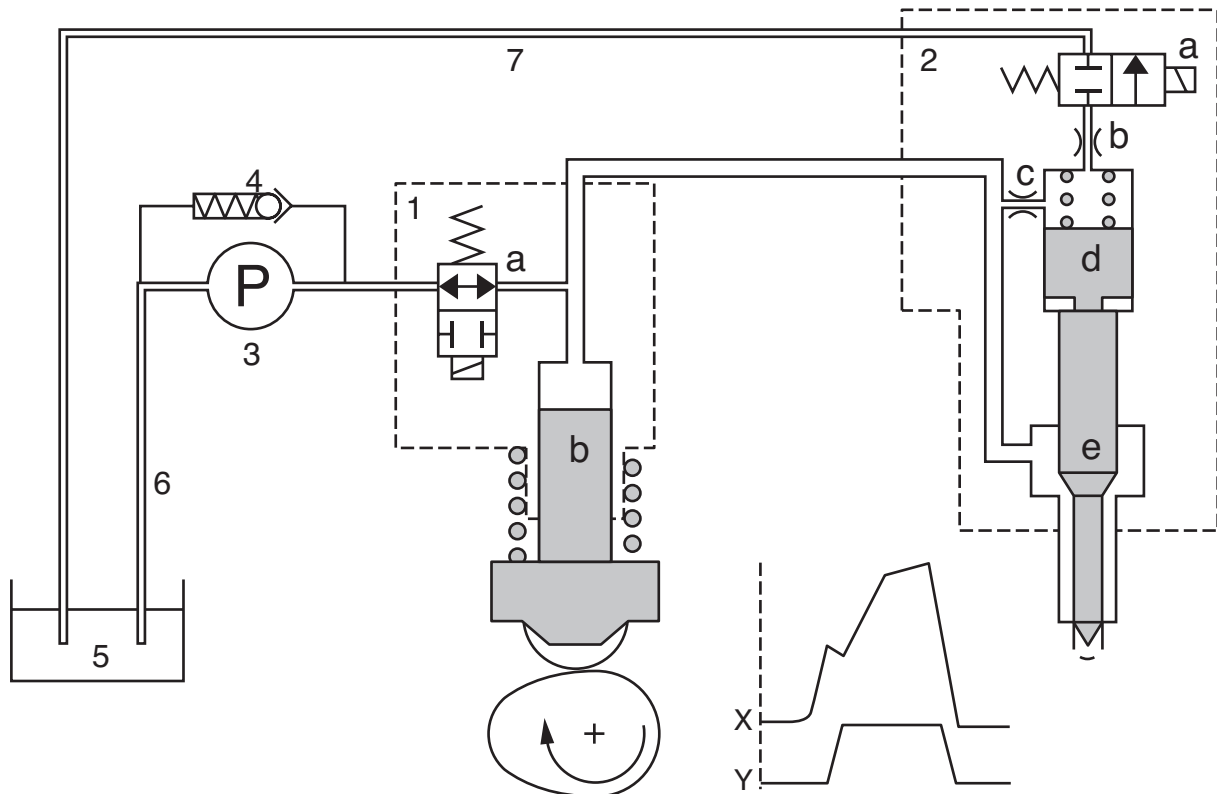

i400795

Filling

The fuel lift pump (3) draws fuel out of the tank (5) via the inlet pipe (6) and pumps it to the pump unit (1). The pump unit has not been activated and the pump unit valve (1a) is open. The space above the pump unit plunger (1b) is filled. Because the camshaft moves the pump unit plunger up, the fuel can now flow back to the supply side. Pressure has not yet built up in the fuel injection pipe.

DMCI ENGINE MANAGEMENT SYSTEM

System description

XF105 series

Pressure increase

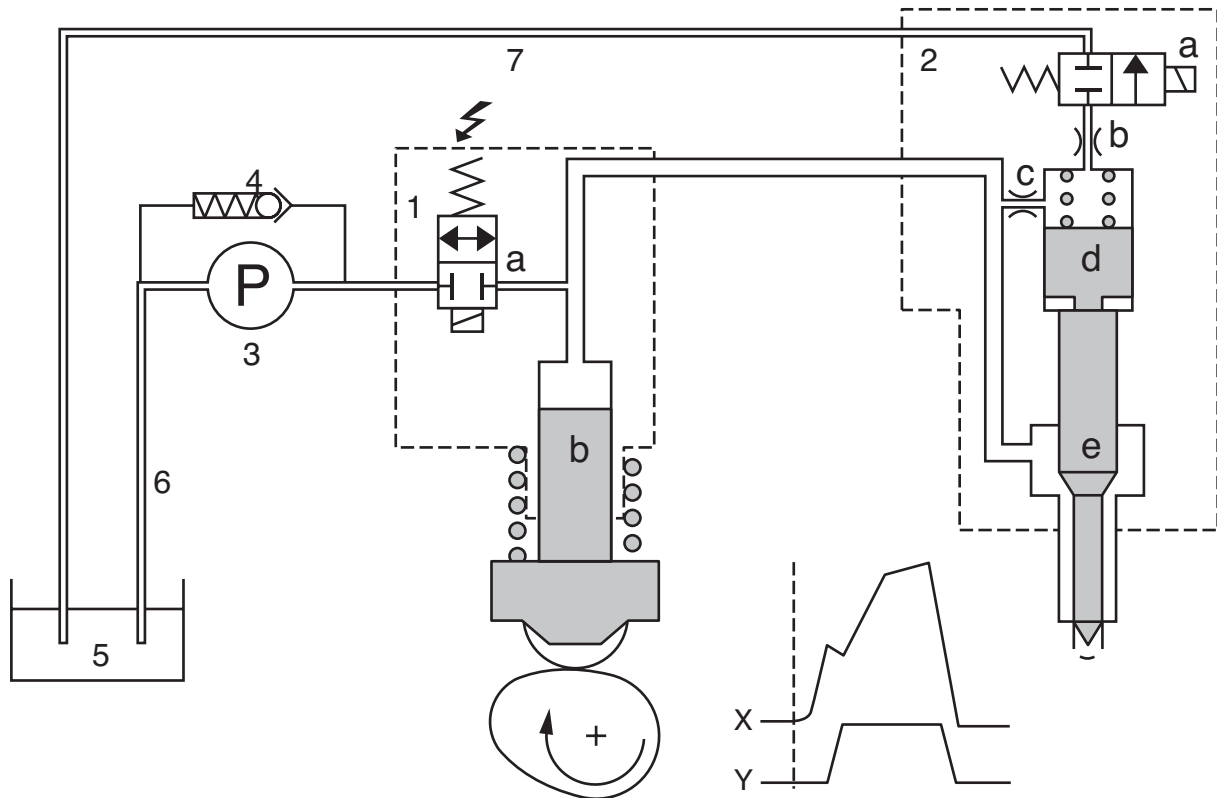

Pressure increase

When the pump unit (1) is activated, the pump unit valve (1a) shuts off the fuel supply. The pump unit plunger (1b) continues to move up, but now pressure builds up because the fuel can no longer flow back to the supply side. The fuel is now pumped to the injector (2). The chamber above the injector plunger (2d) now fills slowly via the throttle (2c). Because the injector valve (2a) has not been activated, the fuel cannot flow out to the return (7). The fuel pressure and the spring above the injector plunger (2d) ensure that the injector needle (2e) cannot be lifted.

Curve x indicates the fuel pressure in the injector. Curve y indicates the movement of the injector needle.

The fuel pressure (x) now increases. The injector needle has not yet lifted (y).

i400796

1

DMCI ENGINE MANAGEMENT SYSTEM

XF105 series

System description

Start of injection

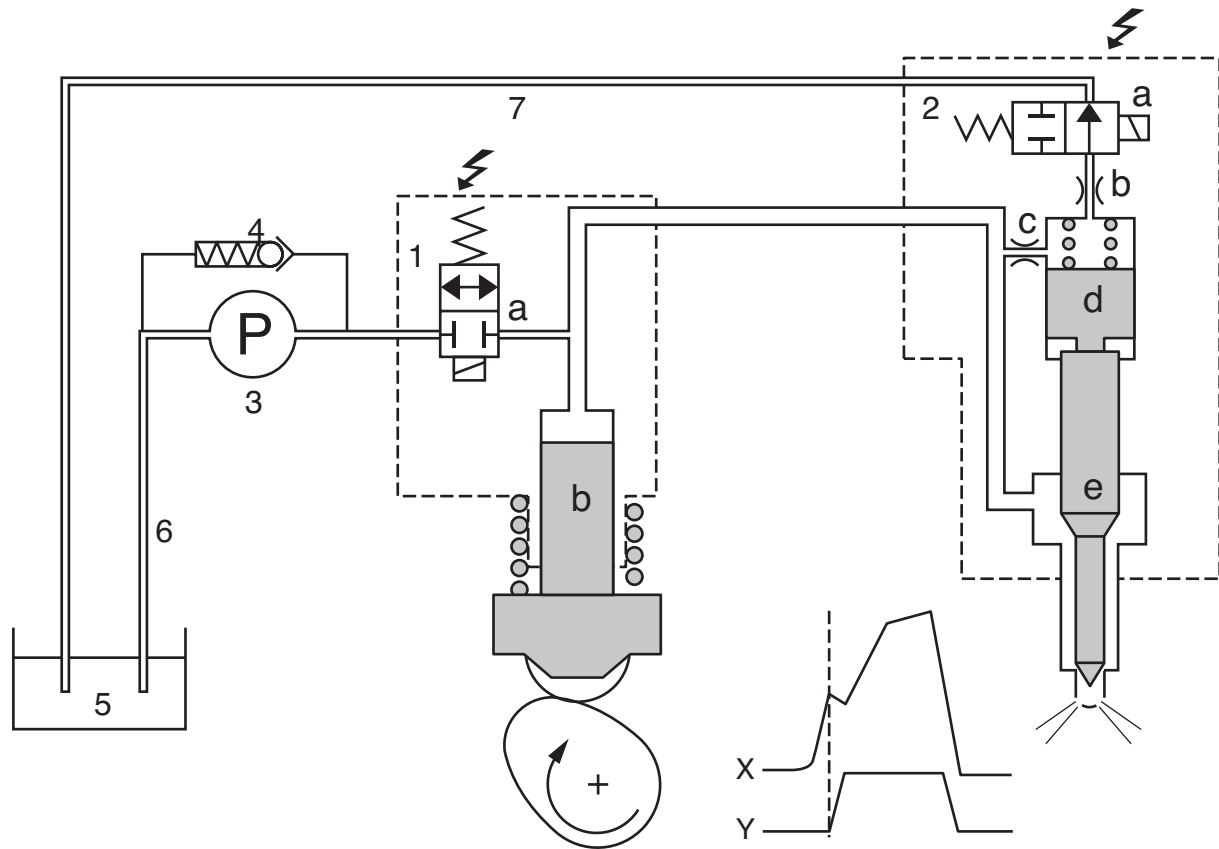

1

Start of injection

When the injector (2) is also activated, the injector valve (2a) releases the path to the return (7). The pressure above the injector plunger (2d) is now slowly released via a throttle (2b). Now the pressure under the injector needle (2e) is able to lift the injector needle. Fuel is now injected. The fuel pressure (x) now experiences a small dip because fuel is being injected, but the pressure immediately rises again. The needle is now lifted (y).

i400797

DMCI ENGINE MANAGEMENT SYSTEM

System description

XF105 series

Pressure reduction

1

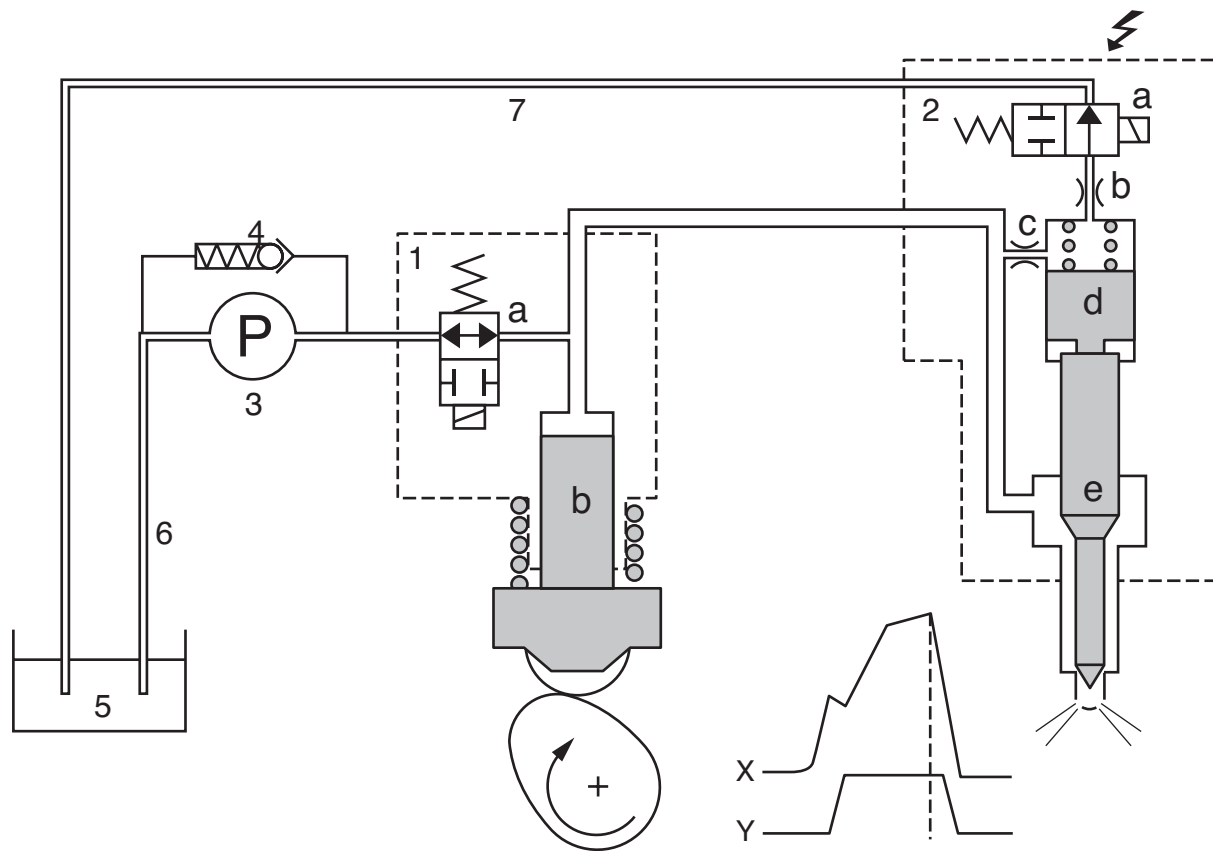

i400798

Pressure reduction

To ensure that the injector needle (2e) closes quickly enough, the fuel pressure in the injector is first reduced. The pump unit (1) is no longer activated and, as a result, the pump unit valve (1a) re-opens the supply and the pressure in the fuel injection pipe drops. Injection still continues. The fuel pressure (x) now decreases. The injector needle is still lifted to its maximum extent (y).

DMCI ENGINE MANAGEMENT SYSTEM

XF105 series

System description

End of injection

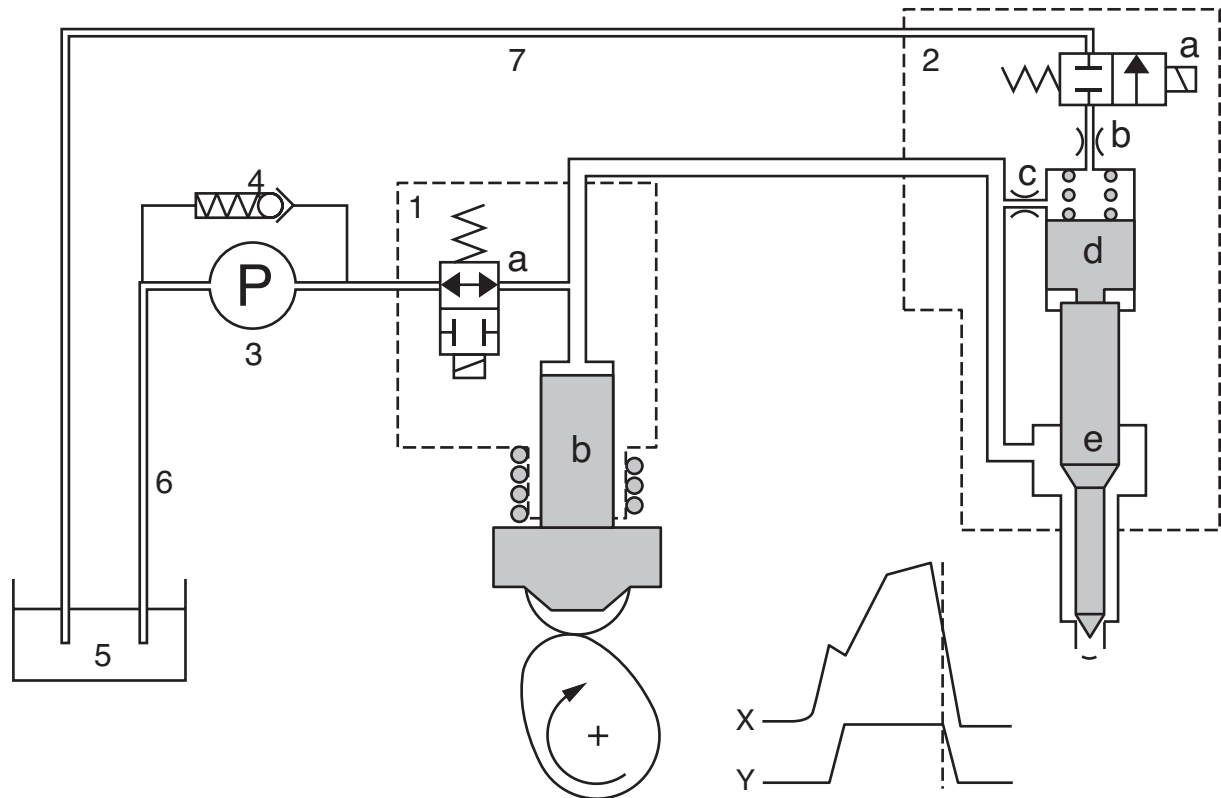

1

End of injection

The injector valve (2a) is now no longer energised. In the meantime, the fuel pressure in the injector has decreased and the injector needle (2e) is closed by the spring above the injector plunger (2d). The fuel pressure (x) now decreases even further. The injector needle is about to close (y).

i400799

DMCI ENGINE MANAGEMENT SYSTEM

System description

XF105 series

Closed

1

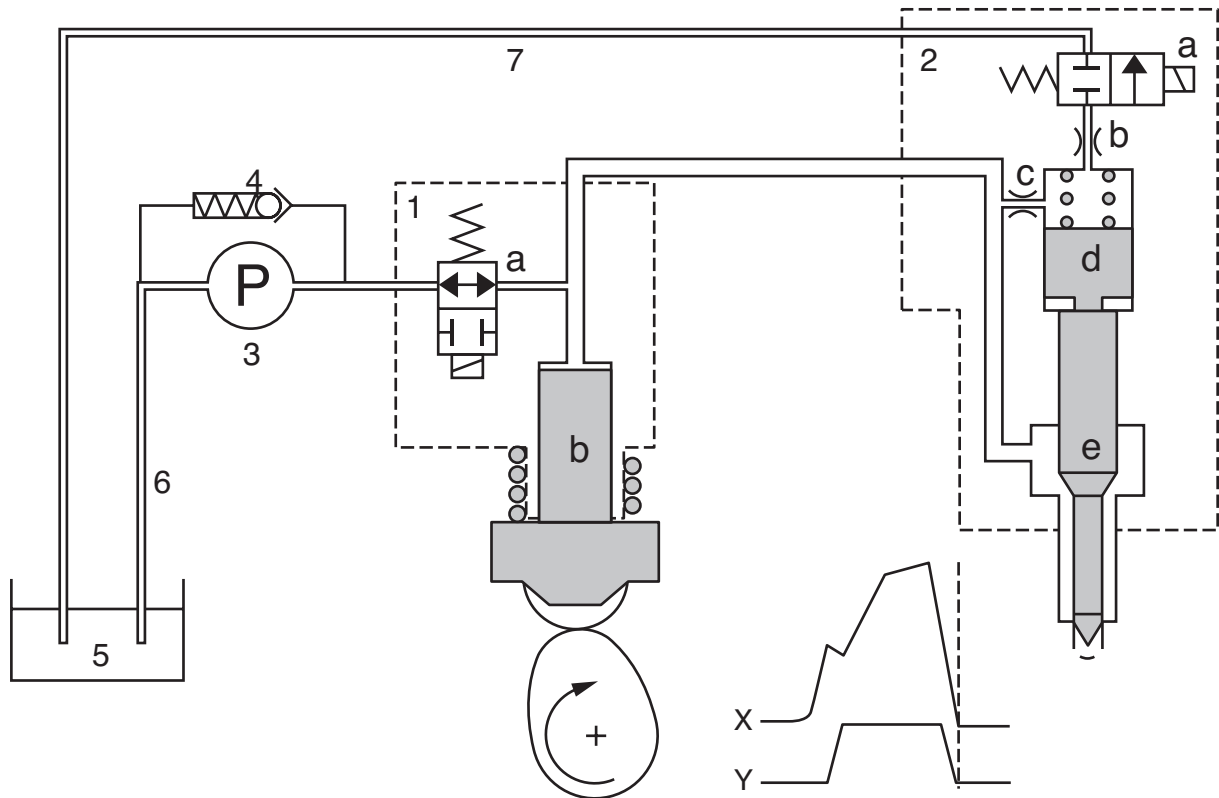

i400800

Closed

The fuel pressure has now dropped as much as possible and the injector needle (2e) is pushed down by the spring above the plunger (d). The fuel pressure (x) is now at its minimum level. The injector needle has closed (y).

DMCI ENGINE MANAGEMENT SYSTEM

XF105 series

Description of components

2. DESCRIPTION OF COMPONENTS

2.1 DMCI ELECTRONIC UNIT

The electronic unit is mounted on the cylinder block using rubber insulating bushes (3). The electronic unit has three 62-pin connectors. Input signals from various sensors are continuously processed and compared with data stored in various maps (tables) in the electronic unit. Actuators are energised on the basis of the signals received and the maps.

The housing (1) of the electronic unit is directly connected to the engine block by an earth cable (2). This earth connection is required because of internal components which protect against radio waves from outside.

The electronic unit incorporates an atmospheric pressure sensor and a temperature sensor. There is an air vent (4) for the atmospheric pressure sensor in the housing of the electronic unit.

An identification sticker (5) is attached to the electronic unit.

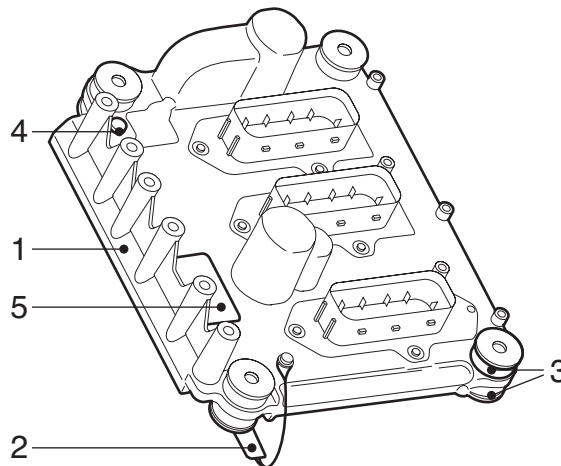

i400785

The effect of atmospheric pressure on the system:

- the quantity of fuel injected when driving at high altitudes (low air pressure).

If atmospheric pressure is low (in mountainous areas), the air is thinner. When the air is thinner it has a low density. The electronic unit uses this information to control the turbocharger pressure and adjust the quantity of fuel to be injected.

The effect of the internal temperature sensor on the system:

- none.

The internal temperature sensor measures the temperature of the electronic unit. If the temperature becomes too high, a fault code is stored. The system does not take any further action on the basis of this information.

Calibration

The performance of pump units and injectors may differ slightly from one another as a result of small production tolerances. These small production differences are compensated for during production by means of calibration in order to optimise the engine output, exhaust gas emissions and handling characteristics. A calibration code is used to program the pump units and injectors into the electronic unit individually. The electronic unit modifies the control of the pump units and injectors on the basis of these calibration codes.

DMCI ENGINE MANAGEMENT SYSTEM

Description of components

XF105 series

2.2 ACCELERATOR PEDAL SENSOR

- 1 Kick-down switch
- 2 Accelerator pedal sensor

The accelerator pedal sensor (F672) is mounted on the accelerator pedal. The sensor (2) consists of a potentiometer and a switch.

Potentiometer

The output signal (B33) from the potentiometer is a linear voltage that has a fixed relationship with the position of the accelerator pedal and therefore is determined by the driver. The potentiometer signal is the basis for determining the quantity of fuel to be injected. The potentiometer has a supply voltage (B34) and an earth (B37) via the electronic unit.

Idling switch

Parallel to the potentiometer also the idling switch is operated by depressing the accelerator pedal. The idling switch is open in the no-load position and is closed when the accelerator pedal is operated. The switch is required for the emergency function, when the potentiometer signal is absent. This emergency function allows the vehicle to be driven to a safe place or a workshop if there is no potentiometer signal. One side of the switch is connected to earth (B38) via the electronic unit. The positive side (B41) is connected to earth by means of the switch.

Kick-down switch

The kick-down switch (1) under the accelerator pedal only acts to form a mechanical resistance when the accelerator pedal is depressed. The electronic unit detects the kick-down status because the value of the output signal from the potentiometer is higher than at full load. The kick-down switch is for instance used to temporarily disengage variable vehicle speed limiting so that an automatic/automated gearbox can shift down (in order to accelerate).

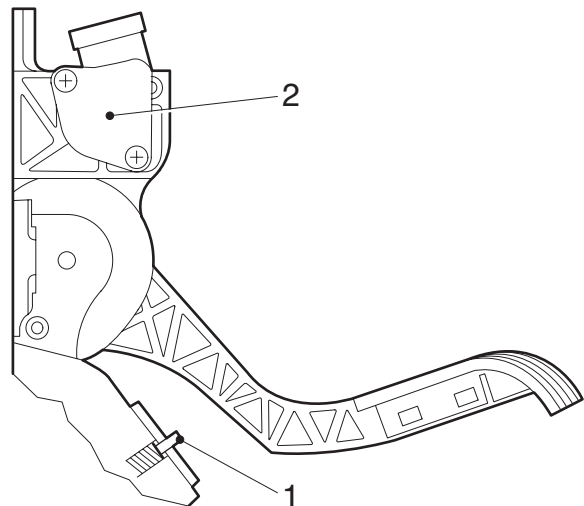
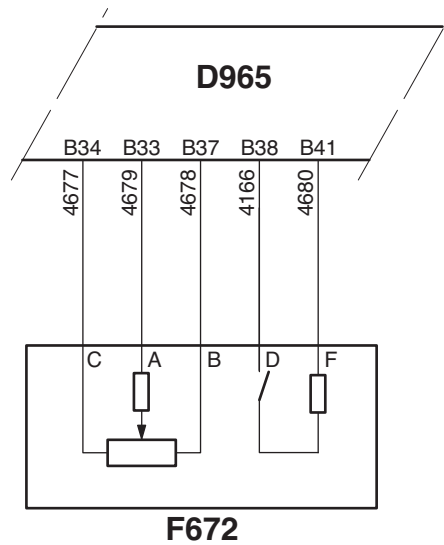

i400694

DMCI ENGINE MANAGEMENT SYSTEM

XF105 series

Description of components

Effect of potentiometer output signal on the system:

- the basis for determining the quantity of fuel to be injected.
- engine brake disengaging/engaging conditions
- disengaging conditions of Downhill Speed Control
- CAN message accelerator pedal position, via V-CAN1 (AS Tronic, AGC-A) and V-CAN2 (EBS-2, VIC-2, builder module);
- CAN message kickdown position active, via V-CAN1 (AS Tronic, AGC-A);

Effect of idling switch output signal on the system:

- emergency function if the potentiometer is not working.
- engine brake disengaging/engaging conditions
- disengaging conditions of Downhill Speed Control
- CAN message idling switch active, via V-CAN1 (AS Tronic) and V-CAN2 (VIC-2, ZF intarder EST-42, EBS-2, DIP-4, builder module)

1

DMCI ENGINE MANAGEMENT SYSTEM

Description of components

XF105 series

1

2.3 COOLANT TEMPERATURE SENSOR

The coolant temperature sensor emits a signal that indicates the temperature of the coolant and therefore indirectly the engine temperature. The sensor used is of the NTC (negative temperature coefficient) type. The higher the temperature, the lower the resistance of the sensor.

Effect of output signal on the system:

- calculation of glowing time;
- calculation of the quantity of fuel to be injected and the injection timing;
- calculation of actuation of the electronically controlled fan clutch;
- limiting of engine torque when temperature is too high;
- CAN message engine temperature, via V-CAN2 to VIC-2 for display on the instrument panel;
- limitation of the maximum engine speed when the engine is cold.

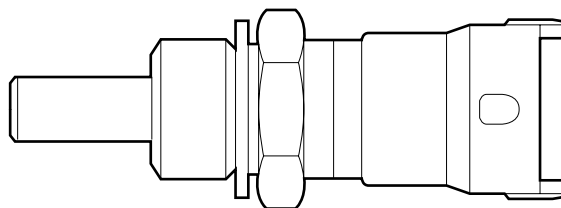

i 400440

2.4 2nd COOLANT TEMPERATURE SENSOR

The 2nd coolant temperature sensor (F743) gives a signal of the temperature of the coolant and therefore indirectly of the engine at the level of cylinder 6. The signal is compared by the electronic unit (D965) to the signal from the coolant sensor (F566) at the level of cylinder 1. The sensor is of the NTC (Negative Temperature Coefficient) type. The higher the temperature, the lower the resistance of the sensor.

Effect of the signal on the system:

- Detection of a cooling problem resulting in engine torque limitation

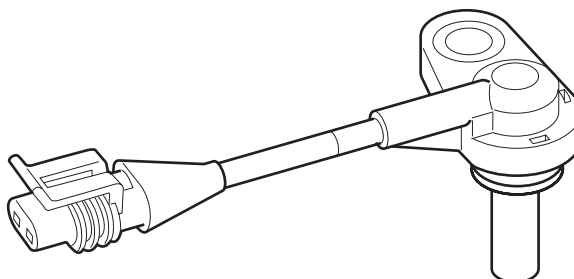

i401003

DMCI ENGINE MANAGEMENT SYSTEM

XF105 series

Description of components

2.5 INLET AIR BOOST PRESSURE AND TEMPERATURE SENSOR

This is a combined sensor that measures the air pressure in the inlet manifold and the temperature of this air. The electronic unit uses this data to calculate the quantity of air drawn in. The quantity of intake air needs to be known in order to calculate the quantity of injected fuel to prevent smoke. The charge pressure is also in a direct relationship to the turbocharger pressure control. The waste gate valve is actuated depending on this signal.

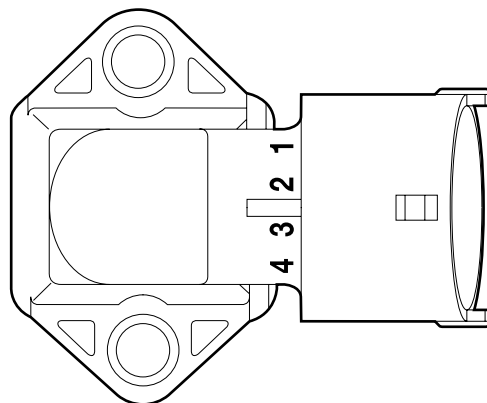
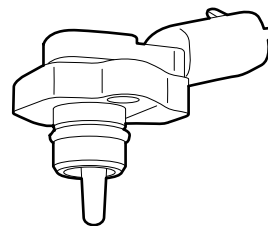

i 400441

- 1 Air inlet pressure sensor, piezo-resistive
- 2 Electrical connection
- 3 Air inlet temperature sensor, NTC
- 4 Air inlet opening
- 5 O-ring
- 6 Accommodation

The charge temperature sensor (3) used is of the NTC (negative temperature coefficient) type. The higher the temperature, the lower the resistance of the sensor. The charge pressure sensor (1) is a piezoresistive sensor. The inlet air is measured via an opening (4) in the sensor. The higher the pressure, the higher the voltage signal. The sensor is sealed in the installation hole in the cylinder head by an O-ring (5).

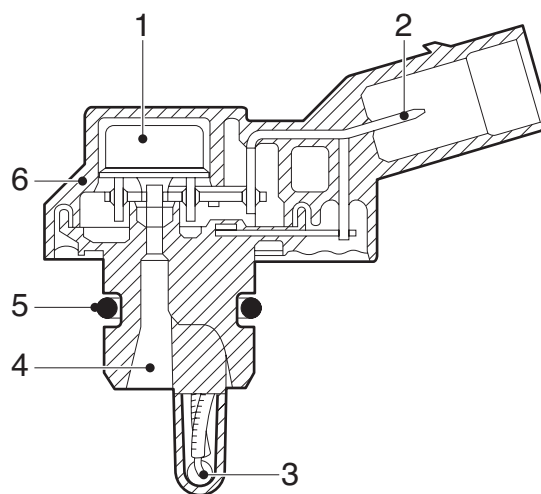

i400742

DMCI ENGINE MANAGEMENT SYSTEM

Description of components

XF105 series

The temperature signal is fed back to the electronic unit via a connection (2).

A piezoresistive sensor requires a power supply (3) and earth (1) to create a linear voltage signal (4).

1

Effect of temperature signal on the system:

- calculation of glowing time;
- correction on the waste gate control;
- correction on the smoke limiting system.

Effect of pressure signal on the system:

- calculation for smoke limiting;
- calculation of the waste gate control;
- protection of turbocharger;
- CAN message to VIC for the charge boost pressure display on the main display of the DIP.

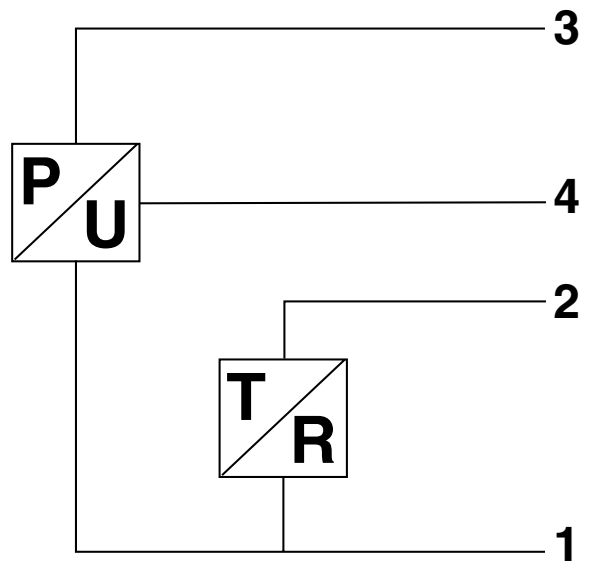

i400534

DMCI ENGINE MANAGEMENT SYSTEM

XF105 series

Description of components

2.6 FUEL PRESSURE AND TEMPERATURE SENSOR

This is a combined sensor that measures the fuel pressure in the fuel gallery and the temperature of this fuel. The sensor is located in the middle of the fuel gallery between the cylinder 3 pump unit and the cylinder 4 pump unit. Because of this the measured values for fuel pressure and temperature are the most representative for the whole fuel gallery.

The fuel temperature sensor is of the NTC (negative temperature coefficient) type. The higher the temperature, the lower the resistance. The fuel pressure sensor is a Piëzo capacitive sensor. The higher the pressure, the higher the voltage signal.

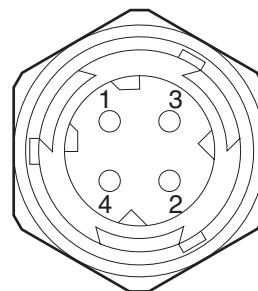
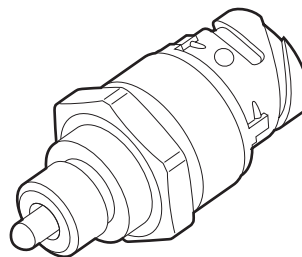

i400792

The temperature signal is fed back to the electronic unit via a connection (3).

A Piëzo capacitive sensor requires a power supply (1) and earth (4) to create a linear voltage signal (2).

Effect of temperature signal on the system:

- correction of quantity of fuel to be injected;
- calculation of glowing time;

Effect of pressure signal on the system:

- enabling fuel pressure to be read on DAVIE;

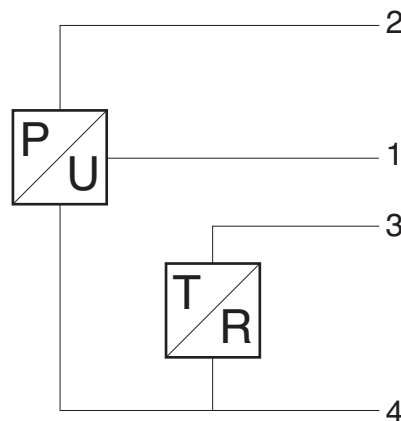

i400791

1

DMCI ENGINE MANAGEMENT SYSTEM

Description of components

XF105 series

2.7 ENGINE OIL PRESSURE AND TEMPERATURE SENSOR

1

This is a combined sensor that measures the engine oil pressure in the cylinder block main passage and the temperature of this oil.

The engine oil temperature sensor used is of the NTC (negative temperature coefficient) type. The higher the temperature, the lower the resistance of the sensor. The engine oil pressure sensor is a Piëzo capacitive sensor. The higher the pressure, the higher the voltage signal. The engine oil pressure is measured via an opening in the sensor. The higher the pressure, the higher the voltage signal.

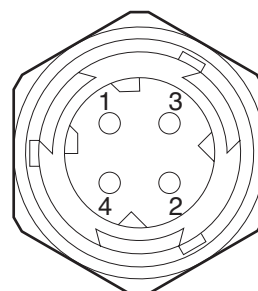
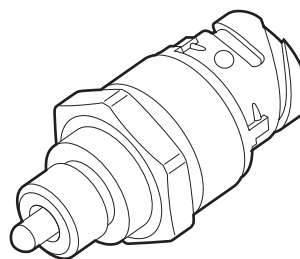

i400792

The temperature signal is fed back to the electronic unit via a connection (3). A piëzo-capacitive sensor requires a power supply (1) and earth (4) to create a linear voltage signal (2).

Effect of temperature signal on the system:

- none.

Effect of pressure signal on the system:

- CAN message to VIC to actuate oil pressure indicator light and warning on the DIP main display when engine oil pressure is too low.

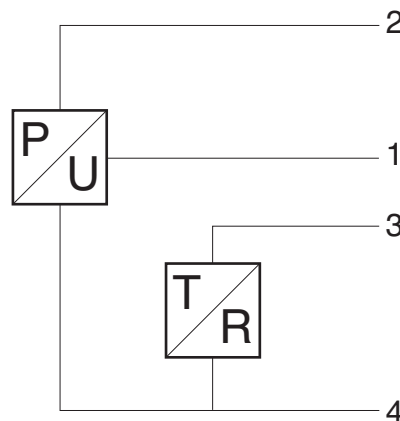

i400791

DMCI ENGINE MANAGEMENT SYSTEM

XF105 series

Description of components

2.8 CRANKSHAFT SENSOR

- 1 Electrical connection, earth
- 2 Electrical connection, signal
- 3 Electrical connection, shield
- A Crankshaft sensor
- B Flywheel housing
- C Magnet
- D Metal core
- E Coil
- F Flywheel
- G Hole pattern

The crankshaft sensor (F552) registers engine speed and is used to determine the injection timing. The crankshaft sensor is responsible, together with the camshaft sensor, for synchronisation when starting the engine. If there is no camshaft signal, the crankshaft signal is used for cylinder detection.

The crankshaft sensor (A) is mounted on the flywheel housing (B). It is an inductive sensor and consists of a magnet (C), a metal core (D) and a coil (E). Inductive means that the sensor can generate an alternating voltage signal independently by means of a changing magnetic field. The pattern of holes in the flywheel (F) means that the sensor can generate a specific alternating signal. The pattern consists of 3 segments each with 18 holes and an area with 2 holes missing (G). Each segment is used for calculations on two specific cylinders (1/6, 2/5 and 3/4).

The sensor has 3 connections. Pins 1 and 2 are responsible for the signal. Pin 2 is the signal connection and pin 1 is the earth connection. Pin 3 is connected to the shield around the signal wires and to the earth connection (pin 1). This prevents the engine speed signal being affected by signals from outside.

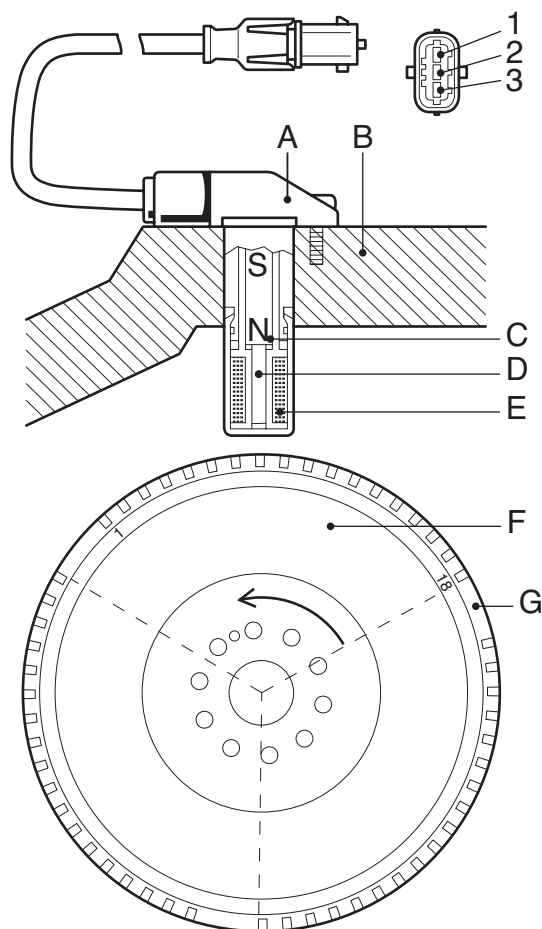

I400731

1

DMCI ENGINE MANAGEMENT SYSTEM

Description of components

XF105 series

1

The most powerful changes in the magnetic field of the sensor take place when the pattern of holes (1) in the flywheel changes from a hole to a tooth and vice versa. A sine-wave alternating voltage (2) is generated as a result of this changing magnetic field. As a hole approaches, the crankshaft sensor signal must be at the maximum positive value and then drop to the maximum negative value as the end of the hole approaches. This is determined by the sensor connections to the electronic unit! The electronic unit converts this sine-wave alternating voltage signal to a digital signal (3) which it uses to carry out calculations.

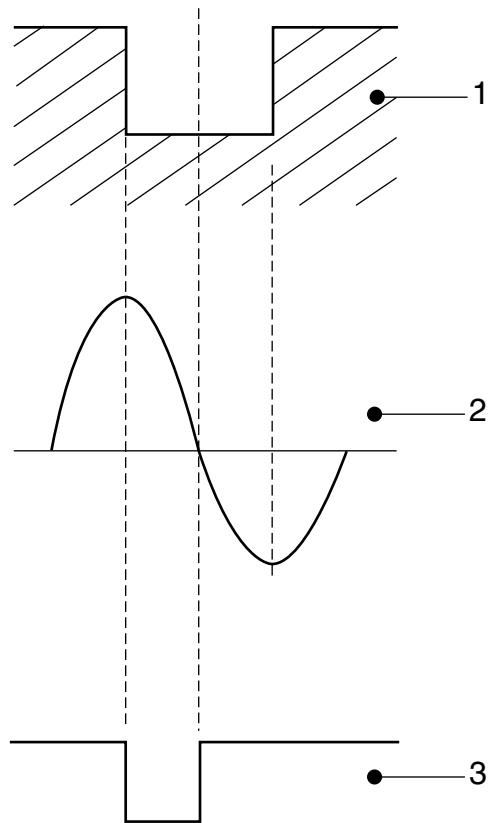

E500606

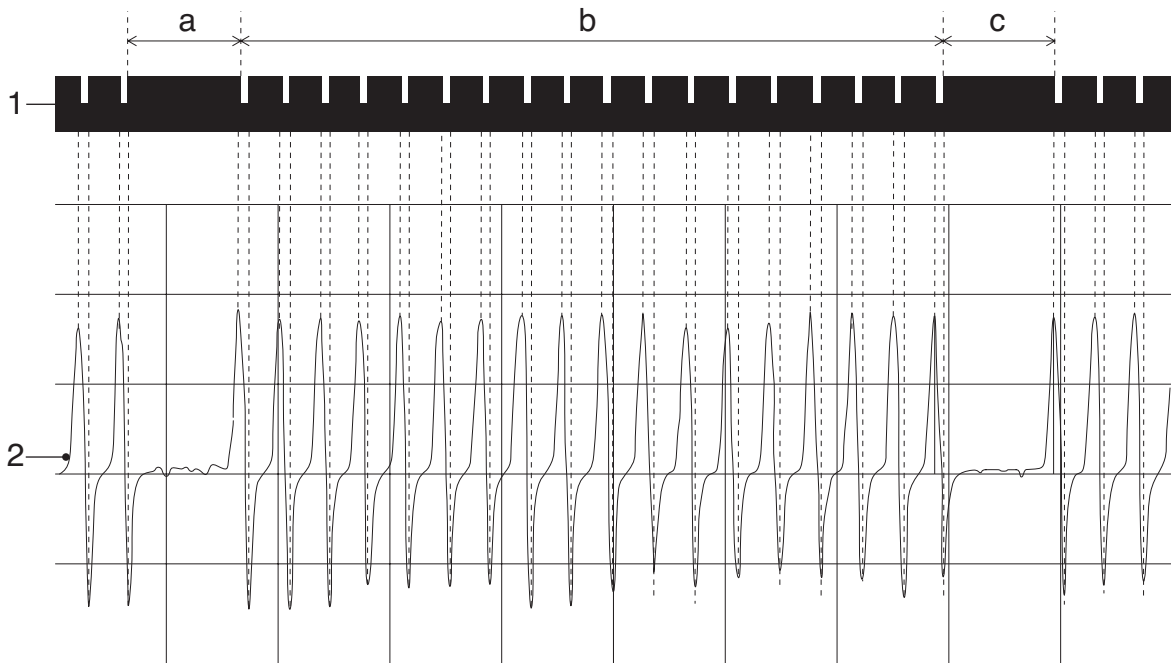

1400732

DMCI ENGINE MANAGEMENT SYSTEM

XF105 series

Description of components

Sine-wave signals (2) can be measured using an oscilloscope with the engine running using the pattern of holes in the flywheel (1). Each hole in a segment (b) generates a sine-wave pulse. When the area with the two holes missing (a and c) goes under the crankshaft sensor, the pulse pattern is interrupted. This enables the sensor to detect the end of the segment.

Effect of output signal on the system:

- synchronisation during starting;
- injection timing calculation;
- registration of engine speed;
- cylinder detection if there is no camshaft signal.
- CAN message engine speed to other vehicle systems via V-CAN1 (AS Tronic, EAS) and V-CAN2 (VIC-2, ZF intarder EST-42, ABS-D, EBS-2, DIP-4, ECAS-4, builder module)
- output signal engine speed (EMAS, cab lead-through connector).

DMCI ENGINE MANAGEMENT SYSTEM

Description of components

XF105 series

2.9 CAMSHAFT SENSOR

1

The camshaft sensor (F558) is responsible, together with the crankshaft sensor, for synchronisation when starting the engine. The signal also provides the information relating to cylinder detection. If the crankshaft sensor (F552) is defective the camshaft signal acts as a reserve signal for registering the engine speed and determining the correct injection timing.

- 1 Electrical connection, signal
- 2 Electrical connection, earth
- 3 Electrical connection, shield
- A Camshaft sensor
- B Flywheel housing
- C Magnet
- D Metal core
- E Coil
- F Pulse wheel

The camshaft sensor (A) is mounted on the flywheel housing (B). It is an inductive sensor and consists of a magnet (C), a metal core (D) and a coil (E). Inductive means that the sensor can generate an alternating voltage signal independently by means of a changing magnetic field. The sensor can generate a specific alternating signal by means of a tooth pattern on the pulse wheel (F). The sensor has 3 connections. Pins 1 and 2 are responsible for the signal. Pin 1 is the signal connection and pin 2 is the earth connection. Pin 3 is connected to the shield around the signal wires and to the earth connection (pin 2). This prevents the signal being affected by signals from outside.

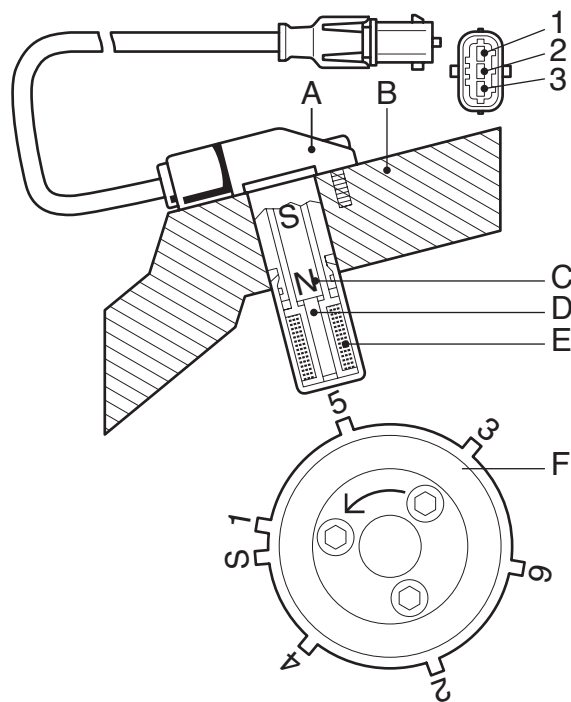

I400761

DMCI ENGINE MANAGEMENT SYSTEM

XF105 series

Description of components

The most powerful changes in the magnetic field of the sensor take place when the tooth pattern (1) on the pulse wheel changes from a tooth to a hole and vice versa. A sine-wave alternating voltage (2) is generated as a result of this changing magnetic field. As a tooth approaches, the camshaft sensor signal must be at the maximum positive value and then drop to the maximum negative value as the end of the tooth approaches. This is determined by the sensor connections to the electronic unit! The electronic unit converts this sine-wave alternating voltage signal to a digital signal (3) which it uses to carry out calculations.

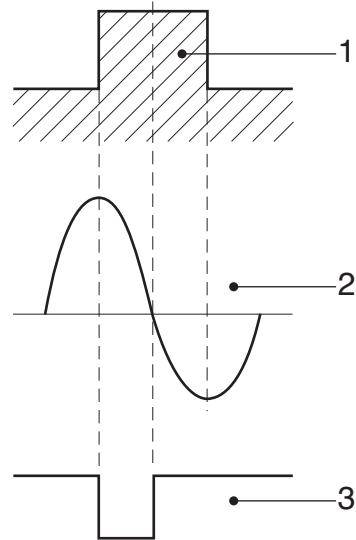

i400839

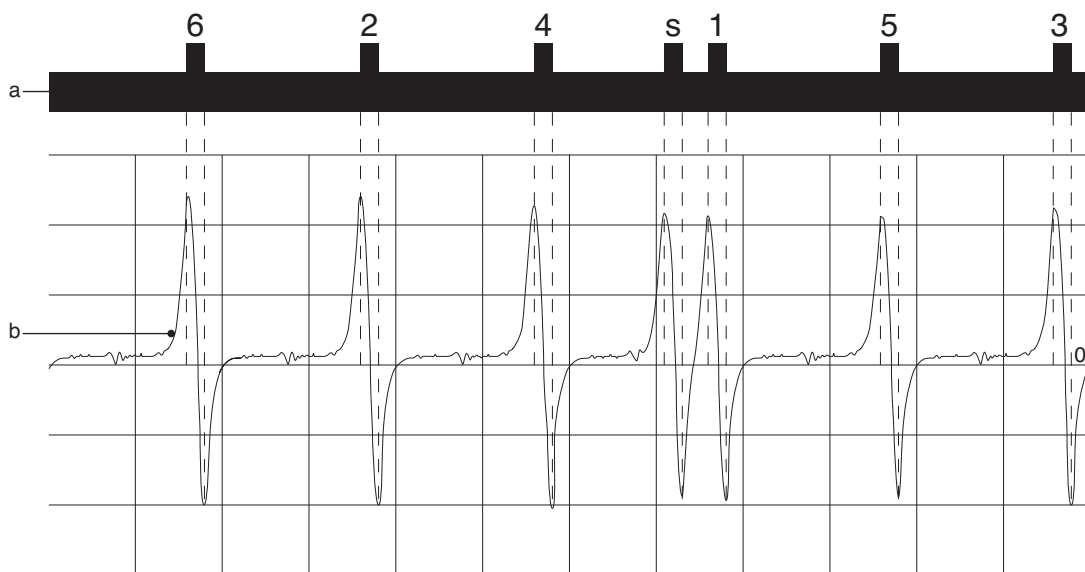

i400762

1

DMCI ENGINE MANAGEMENT SYSTEM

Description of components

XF105 series

1

Sine-wave signals (2) can be measured using an oscilloscope with the engine running using the tooth pattern on the pulse wheel (1). Each tooth, and therefore pulse, corresponds to a specific cylinder. The additional tooth before the cylinder -1 tooth is the synchronisation tooth (S). The pulse this generates is required to realise the synchronisation procedure together with the crankshaft sensor signal.

Effect of output signal on the system:

- synchronisation during starting;
- cylinder detection;
- calculation of injection timing if crankshaft sensor is defective;
- registration of engine speed if crankshaft sensor is defective.
- CAN message engine speed to other vehicle systems if the crank shaft sensor is faulty via V-CAN1 (AS Tronic, EAS) and V-CAN2 (VIC-2, ZF intarder EST-42, ABS-D, EBS-2, DIP-4, ECAS-4, builder module)
- output signal engine speed if crankshaft sensor is faulty (EMAS, cab lead-through connector).

DMCI ENGINE MANAGEMENT SYSTEM

XF105 series

Description of components

2.10 WASTE GATE VALVE

- 1 Electrical connection
- 2 Internal electronics
- 3 Coil
- 4 Core
- 5 valve
- 6 Air connection, supply(1)
- 7 Vent (3)
- 8 Piston
- 9 Air connection, waste gate (2) control pressure
- 10 Accommodation
- 11 Internal pressure sensor

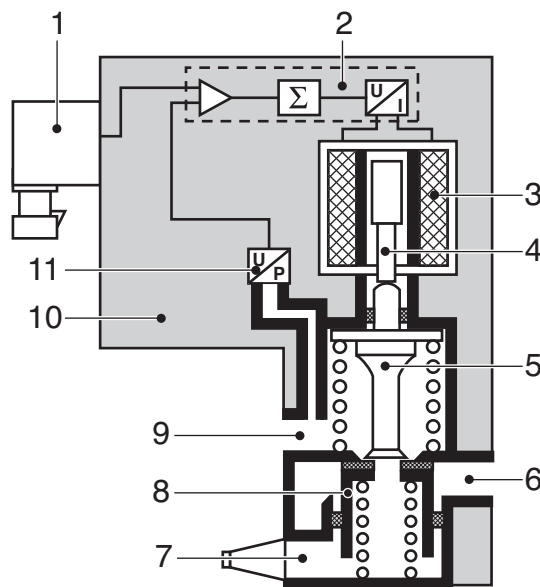

i400741

The waste gate valve controls opening and closing of the waste gate on the turbocharger. The waste gate valve air supply (6) comes directly from the air supply unit circuit 4 (approx. 10 bar) and is adjusted in the valve to a control pressure (9) for the diaphragm housing of the waste gate. The waste gate valve checks the output pressure using an internal pressure sensor (11). The signal issued by the internal pressure sensor is compared by the internal electronics (2) to the signal from the electronic unit. The internal electronics energises the coil (3) with a duty cycle (PWM) signal. If the required pressure differs from the actual pressure, the internal electronics modifies the duty cycle.

Rest position/bleeding

In the rest position or during bleeding, the coil (3) is not energised. The piston (8) and valve (5) are pushed up by the force of the spring. This also pushes up the metal core (4). The outlet (9) is now connected to the air bleed vent (7).

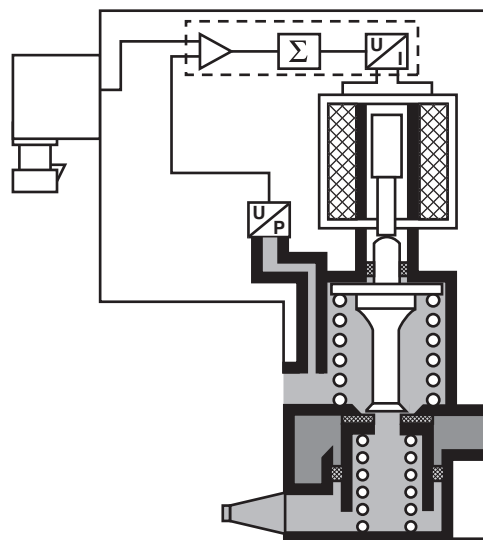

i400745

DMCI ENGINE MANAGEMENT SYSTEM

Description of components

XF105 series

1

Constant pressure

When the coil (3) is energised, the metal core (4) is pushed down. The valve (5) closes off the opening to the air bleed vent on the piston (8). The pressure present in the outlet (9) now stays constant.

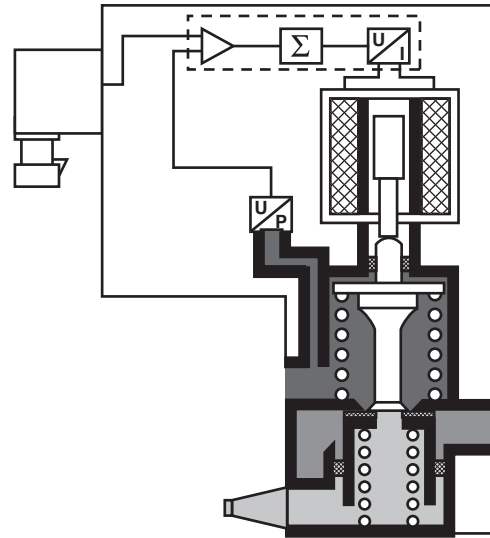

i400746

Pressure increase

If the coil (3) remains activated for longer, the valve (5) will push the piston (8) further down and the air supply opening (6) to the outlet (9) is released. This increases the output pressure.

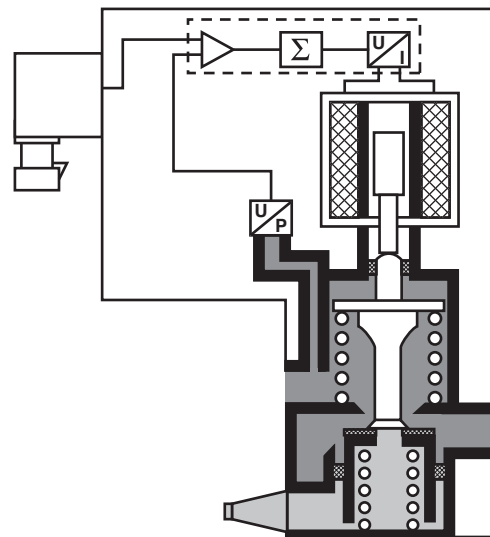

i400747

DMCI ENGINE MANAGEMENT SYSTEM

XF105 series

Description of components

2.11 PUMP UNIT

General

- A. Fuel gallery opening
- B. Return opening
- C. Injector inlet connection
- 1. Lid
- 2. Coil
- 3. Pump unit housing
- 4. Spring
- 5. Plunger
- 6. Roller tappet
- 7. Delivery valve
- 8. Electrical connection

The pump unit supplies fuel to the injector. The pump unit consists of a metal housing (3) in which an electrical coil (2) opens a valve (1). In the rest position, the valve (1) is pushed up by a spring (4). The electrical connection (8) is screwed onto the outside of the pump unit. The roller tappet (6) rotates around the camshaft and actuates the plunger (5), which builds up the fuel pressure. The fuel enters the pump unit via the fuel gallery opening (A). This opening goes into the fuel supply gallery in the engine block. The fuel leaves the pump unit in the direction of the injector via a delivery valve (7). The fuel pipe is fitted to the injector supply connection (C). Leak-off/lubricating fuel from the plunger is fed back to the return gallery in the engine block via the return opening (B).

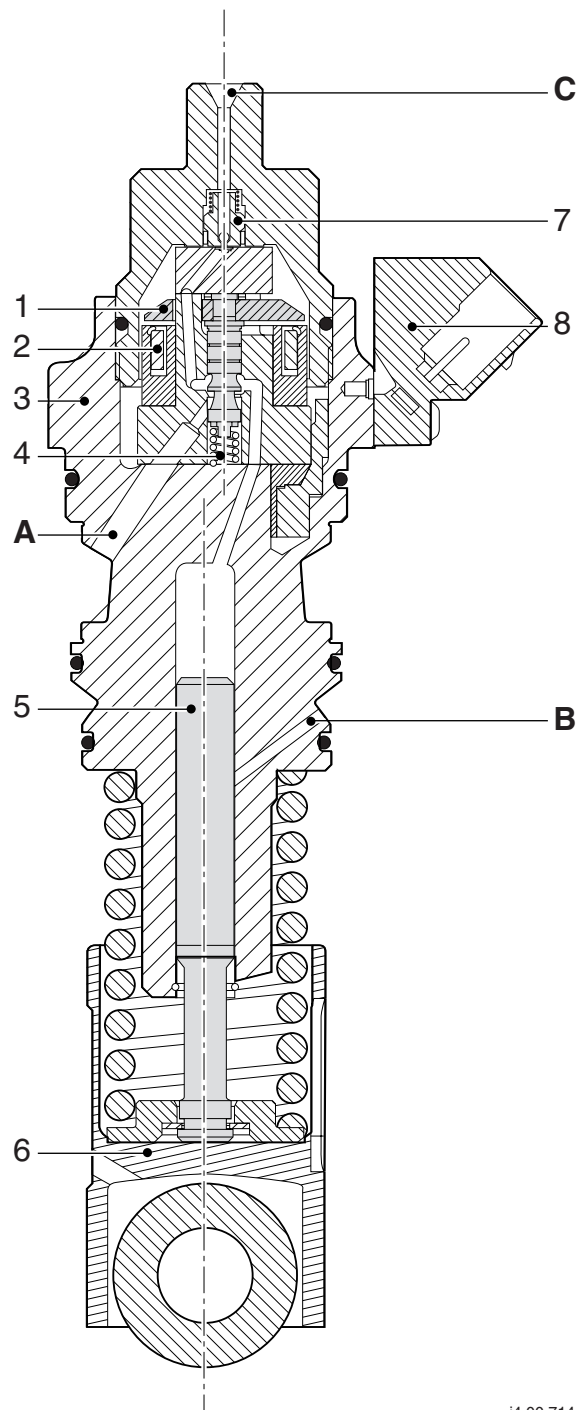

i4 00 714

DMCI ENGINE MANAGEMENT SYSTEM

Description of components

XF105 series

Electrical control

The pump unit is activated with a voltage of approximately 50V. This voltage is the discharge from a capacitor in the DMCI electronic unit. The current increases rapidly because of this relatively high voltage. As a result, the valve in the pump unit opens quickly. This is the pick-up phase. If the current were not limited, it would become too high and damage the coil in the pump unit. The increase in the current is limited by switching to pulsating control of approximately 24V after discharging the capacitor. This is the withstand phase. The current now remains high enough to hold the valve open. The length of the pick-up phase stays practically the same under all circumstances. The length of the withstand phase will vary depending on the calculations carried out by the electronic unit. When the pump unit is deactivated a negative induction peak is created by switching off the current through the pump unit coil.

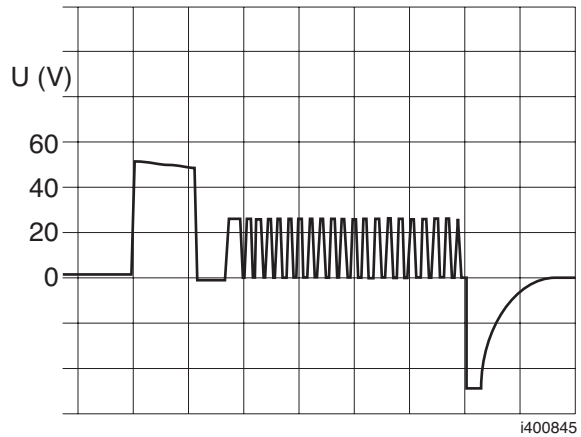

Operation

The fuel is supplied to the pump unit via the gallery in the engine block flowing towards the delivery chamber above the plunger. The delivery chamber now fills.

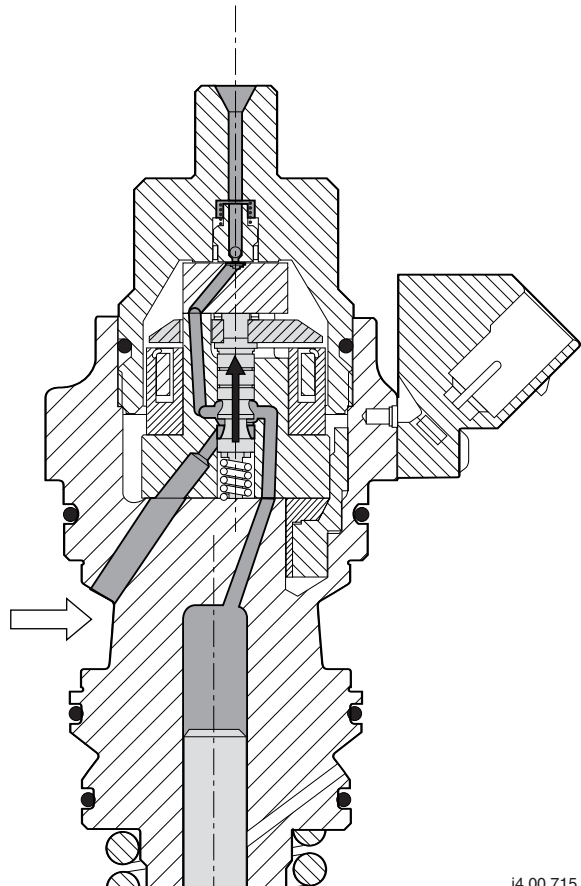

DMCI ENGINE MANAGEMENT SYSTEM

XF105 series

Description of components

The pressure does not build up immediately when the plunger is pushed up by the camshaft. The fuel can still flow back to the fuel gallery via the supply opening.

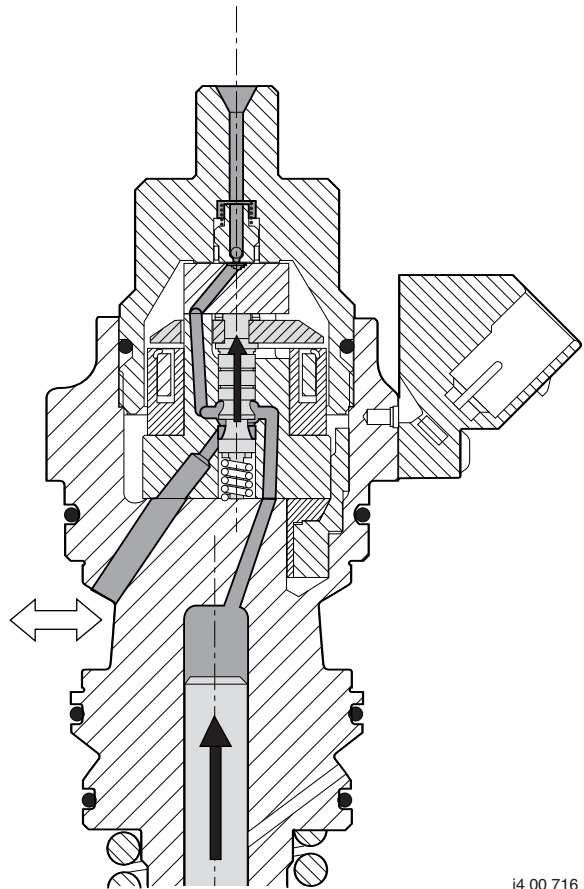

i4 00 716

1

DMCI ENGINE MANAGEMENT SYSTEM

Description of components

XF105 series

When the coil is activated, the valve is pulled down and the opening to the fuel gallery closes. Pressure only starts to be built up by the plunger now. The fuel cannot flow back to the gallery and now has to flow towards the injector outlet via the delivery valve. Fuel is now supplied to the injector.

1

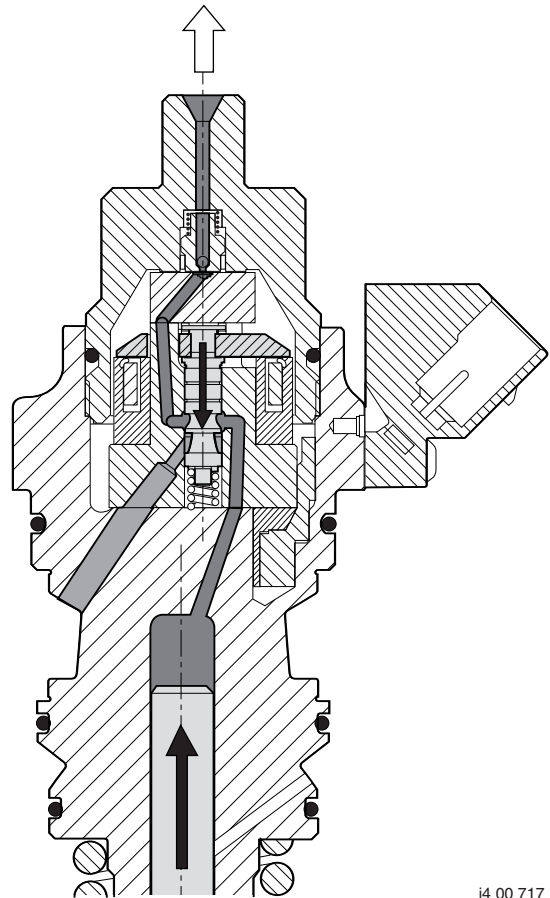

i4 00 717

DMCI ENGINE MANAGEMENT SYSTEM

XF105 series

Description of components

When the coil is deactivated by the electronic unit, the valve is pushed up again by the spring and the opening to the fuel gallery is released again. This stops the supply of fuel to the injector.

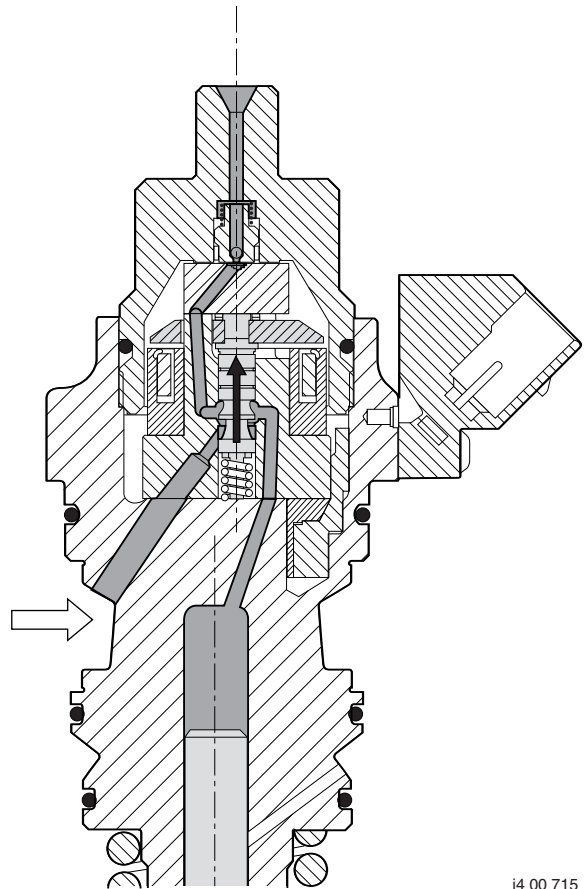

i4 00 715

1

DMCI ENGINE MANAGEMENT SYSTEM

Description of components

XF105 series

Every pump unit is calibrated after production to compensate for any inaccuracies/differences in production. There is a 4-letter calibration code on the housing of the electrical connections. The code must be programmed into the electronic unit so that the unit can optimise controls for fuel injection. If the pump unit is replaced or moved, the calibration code must be programmed into the electronic unit again using DAVIE XD.

1

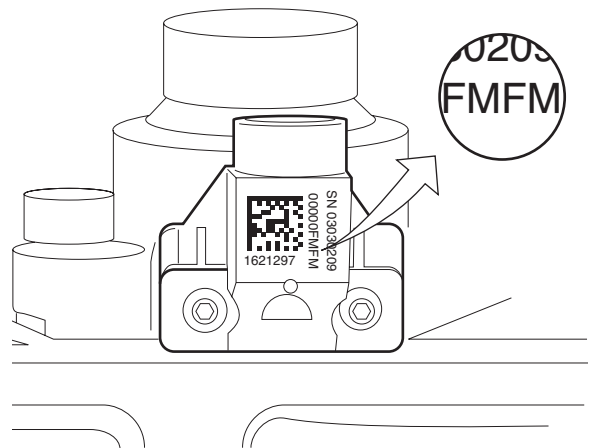

i400771

DMCI ENGINE MANAGEMENT SYSTEM

XF105 series

Description of components

2.12 INJECTOR

General

- A. Fuel supply
- B. Return opening
- 1. Injector body
- 2. O-ring
- 3. O-ring
- 4. Nozzle holder
- 5. Washer
- 6. Nozzle
- 7. Electrical connection
- 8. Bar filter
- 9. Spring
- 10. Coil
- 11. Valve
- 12. Plunger
- 13. Plunger spring
- 14. Injector needle

The pump unit supplies fuel to the injector. The injector consists essentially of two parts. The top part is a metal housing (1), to which the electrical connector (7) is attached. The coil (10) and spring (9) that open and close the valve (11) are also in the housing. The bottom part bears the closest resemblance to a conventional injector. The valve (11) and its guide are in this part, the nozzle holder (4). Below this are the plunger (12) and spring (13) and finally the nozzle (6), with the injector needle (14) inside. The copper washer (5) is under the nozzle holder.

The fuel enters the injector via the supply (A), in which the bar filter (8) is pressed. The return fuel leaves the injector via the opening (B) and flows into the cylinder head return duct.

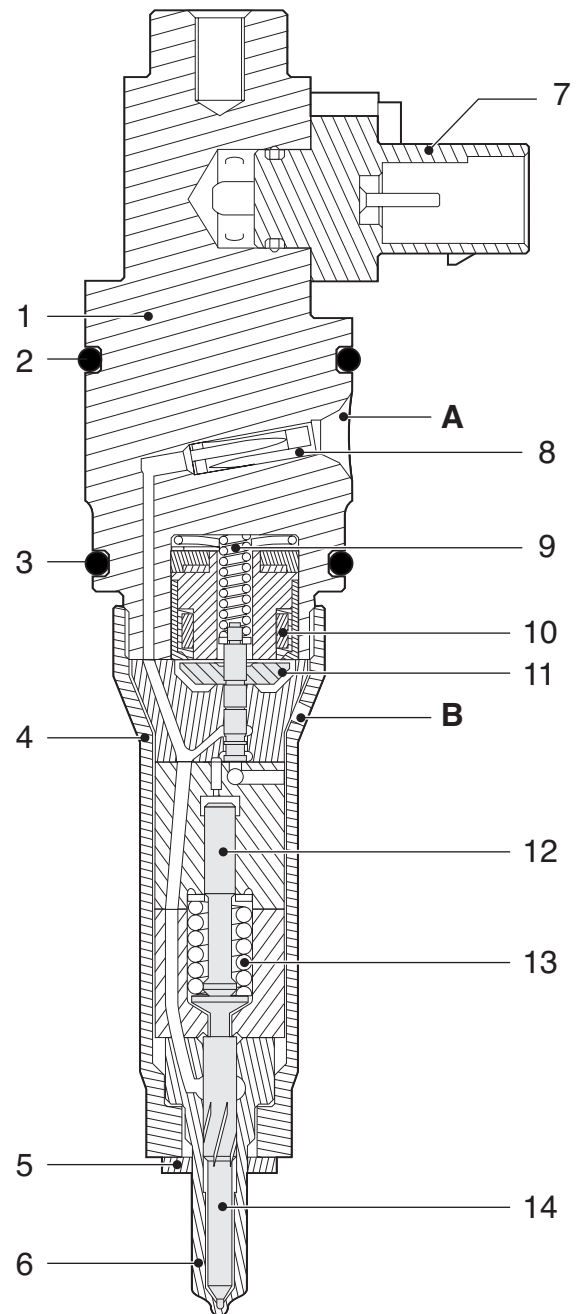

i400721

DMCI ENGINE MANAGEMENT SYSTEM

Description of components

XF105 series

Electrical control

The injector is activated with a voltage of approximately 50V. This voltage is the discharge from a capacitor in the DMCI electronic unit. The current increases rapidly because of this relatively high voltage. As a result, the valve in the injector opens quickly. This is the pick-up phase. If the current were not limited, it would become too high and damage the coil in the injector. The increase in the current is limited by switching to pulsating control of approximately 24V after discharging the capacitor. This is the withstand phase. The current now remains high enough to hold the valve open. The length of the pick-up phase stays practically the same under all circumstances. The length of the withstand phase will vary depending on the calculations carried out by the electronic unit. When the pump unit is deactivated a negative induction peak is created by switching off the current through the injector coil.

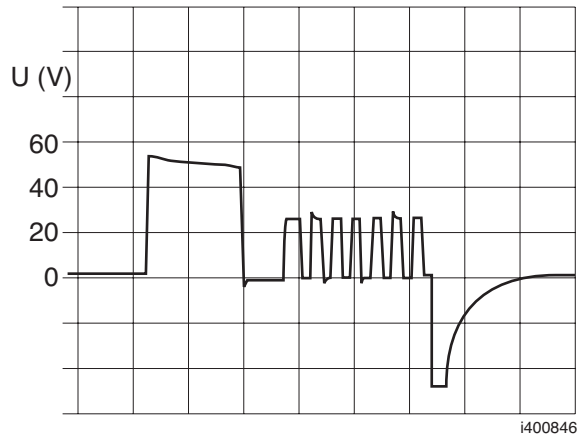

i400846

Operation

In the rest position, the valve is pushed down by the spring above the valve. The opening to the return is now closed.

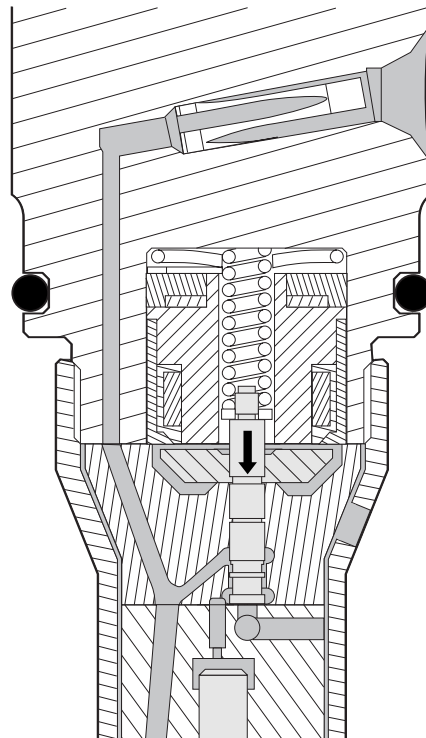

i4 00 722

1

DMCI ENGINE MANAGEMENT SYSTEM

XF105 series

Description of components

Even though fuel is now being supplied to the injector, this does not mean that it immediately starts injecting. The same fuel pressure that must lift the injector needle also pushes down the plunger - along with the plunger spring. The injector needle cannot yet be lifted.

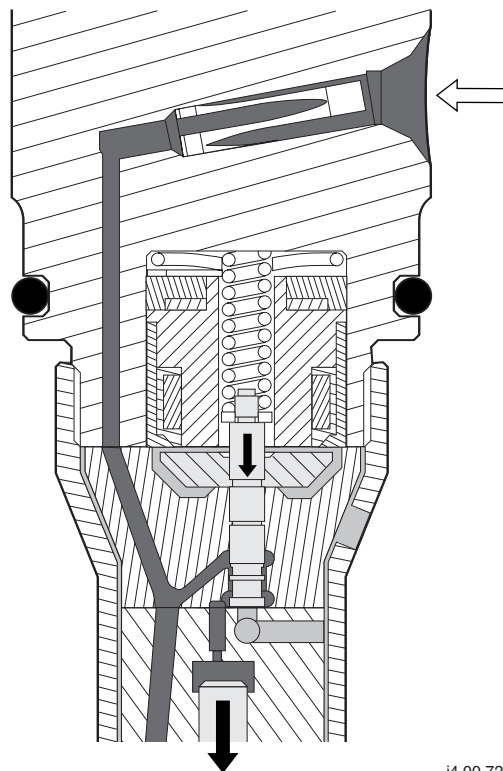

i4 00 723

When the coil is activated by the electronic unit, the valve is pulled in against the pressure of the spring and the opening to the return is released. As a result, the pressure above the plunger decreases. The fuel pressure under the injector needle now overcomes the pressure of the spring above the plunger. The injector needle is lifted and fuel is injected.

To stop injection, the fuel supply pressure to the injector is decreased by deactivating the pump unit. The injector is only deactivated once the fuel pressure is low enough. This is to allow the plunger spring to close the injector needle quickly.

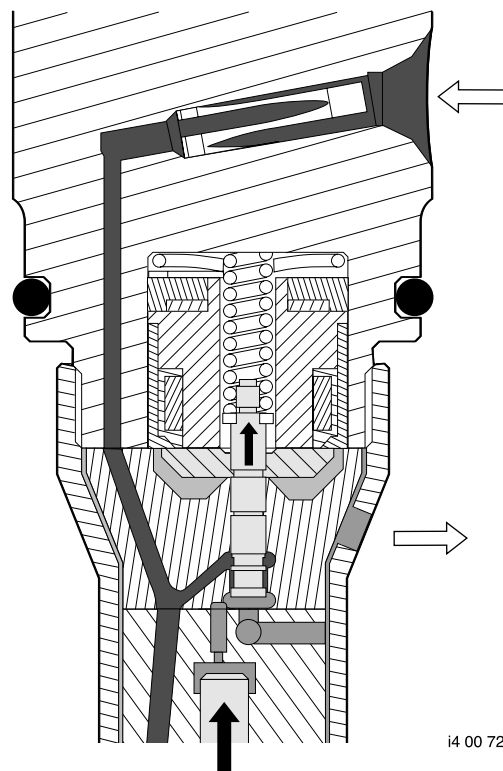

i4 00 724

1

DMCI ENGINE MANAGEMENT SYSTEM

Description of components

XF105 series

Every injector is calibrated during production to compensate for any inaccuracies/differences in production. There is a 6-letter calibration code on the housing of the electrical connections. The code must be programmed into the electronic unit so that the unit can optimise controls for fuel injection. As a result, the electronic unit can ensure that the injection timing and the quantity of fuel injected do not differ. If the injector is replaced or moved, the calibration code must be programmed into the electronic unit using DAVIE XD.

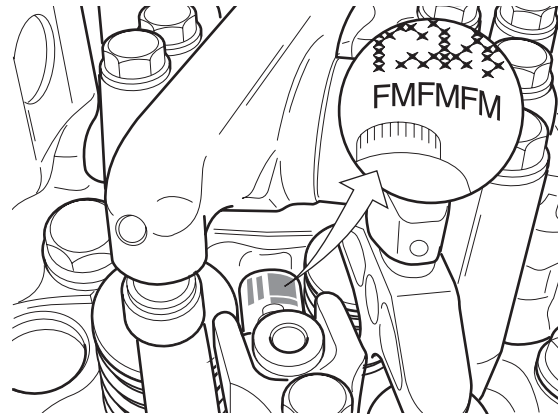

i400772

1

DMCI ENGINE MANAGEMENT SYSTEM

XF105 series

Description of components

2.13 ELECTRONICALLY CONTROLLED FAN CLUTCH

- 1 Stator
- 2 lid
- 3 Rotor
- 4 Coil
- 5 Drive shaft
- 6 Supply chamber
- 7 Working area

An electronically controlled fan clutch is used for accurate control of the fan speed.

The electronically controlled fan clutch checks and controls the fan speed to ensure that the flow of cooling air through the cooling system is sufficient to keep the coolant temperature and/or inlet air temperature within certain limits.

The coil (4) fitted to the drive shaft (5) with bearings generates a magnetic field. The duty cycle to the coil (4) will be modified depending on the variables stated above. This will cause changes in the magnetic field and the valve (2) will be attracted either more or less.

Control of the fan clutch depends on various factors:

- coolant temperature
- the inlet air temperature
- vehicle speed
- engine speed
- fan speed
- interarder activation
- internal slip of the fan clutch (slip heat protection)

The fan clutch consists of a stator (1) and the rotor (3), which is fixed to the drive shaft (5). It also includes the supply chamber (6) for the silicone fluid.

The working area is located between the stator (1) and the rotor (3). The fan is fitted to the stator (1) and rotates freely around the drive shaft (5).

The speed of the fan is sensed by an internal Hall sensor and a pulse disc.

This sensor sends a signal to the electronic unit DMCI. The electronic unit uses this signal to check the internal slip of the fan and the response to controls.

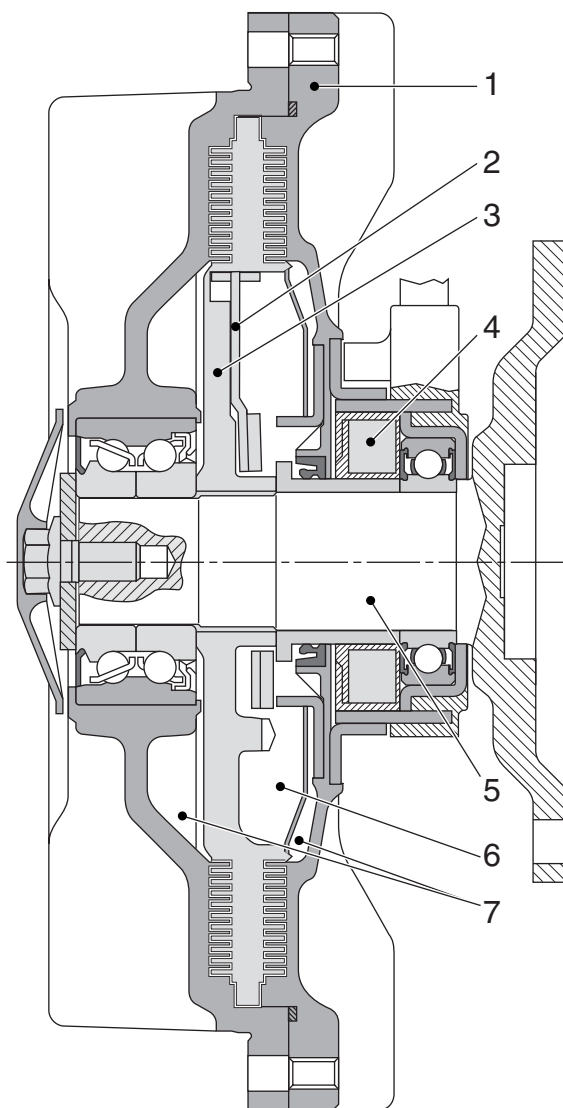

1401012

1

DMCI ENGINE MANAGEMENT SYSTEM

Description of components

XF105 series

Operation

Fan clutch not actuated

The lid (2) is now in the original position. The filler opening is now released and the return opening is closed. The quantity of silicon fluid through the working area (7) between the stator (1) and the rotor (3) increases because of this. The friction in the working area between the stator (1) and the rotor (3) will increase and the difference in rotating speed (slip) between the stator (1) and the rotor (3) will decrease. The fan speed is increased because of this. The fan speed will approach or exceed the engine speed depending on the transmission between the crankshaft and the fan drive.

Note:

This therefore means that in the event of the failure of the actuation of the fan clutch the fan will turn at maximum speed.

Not actuated

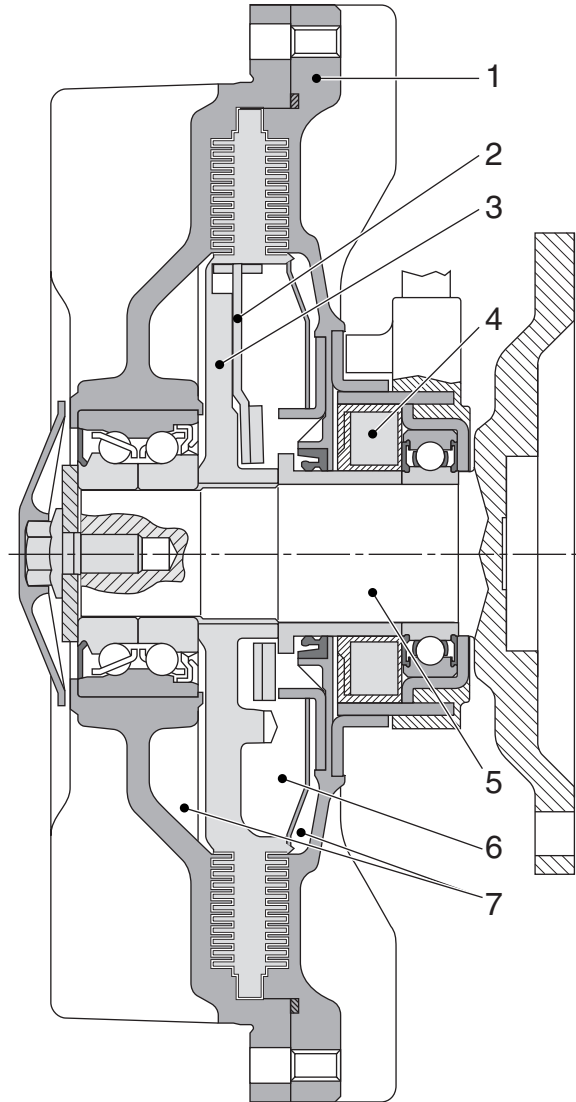

i401012

1

DMCI ENGINE MANAGEMENT SYSTEM

XF105 series

Description of components

Fan clutch actuated

If the coil (4) is actuated by way of a duty-cycle then the lid (2) will be attracted by the magnetism created. The filler opening is then closed by the lid (2) and at the same time the return opening is opened up. The silicon fluid now flows from the working area (7) between the stator (1) and the rotor (3) to the supply chamber (6). Less silicon fluid in the working area means more slip between the stator (1) and the rotor (3). The fan speed will decrease.

Note:

Duty cycle high means decreasing fan speed.
Duty cycle low means increasing fan speed.

Actuated

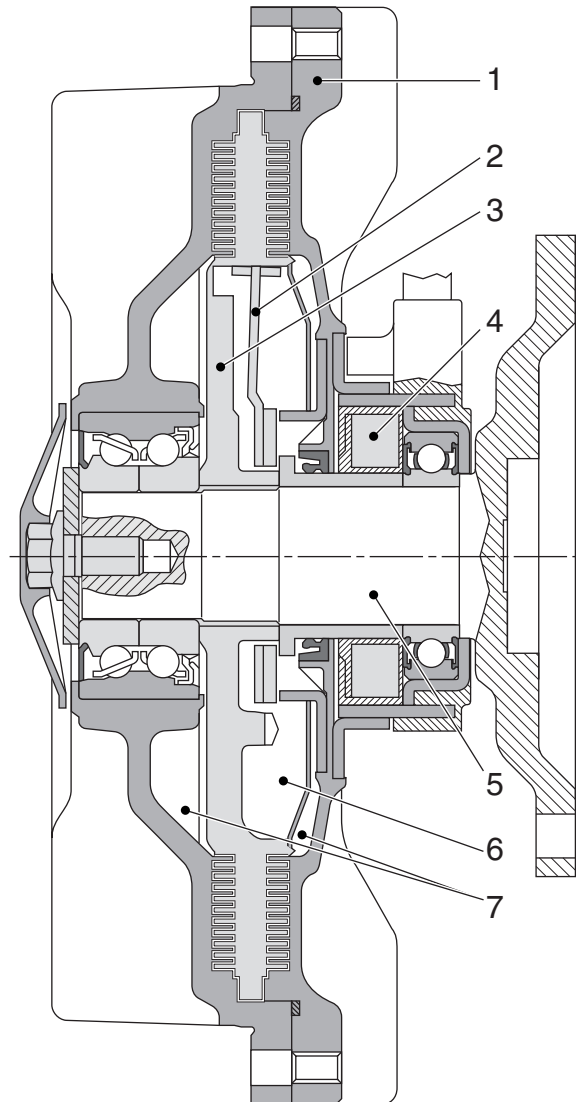

i401013

1

DMCI ENGINE MANAGEMENT SYSTEM

Description of components

XF105 series

1

DMCI ENGINE MANAGEMENT SYSTEM

XF105 series

Control functions

3. CONTROL FUNCTIONS

3.1 SYSTEM STATUS

When carrying out calculations, the electronic unit always starts with a specific engine "status". This status is a specific operating mode of the engine. Controls are used or modified depending on the status.



System status	Description
On (STATIONARY)	The ignition is switched on, the engine has not yet started and is not running.
Starting (CRANKING)	The engine is started.
Idling (IDLING)	The engine is running at idling speed.
Engine running (RUNNING)	The engine is running at speeds higher than idling speed.
Cruise (CRUISE)	The engine is running in the cruise control function, or a control that adjusts the injection controls to keep the vehicle speed constant.
PTO (PTO)	The engine is running in the engine speed control, or a control that keeps the engine speed constant for driving power take off devices.
Overrevving (OVERSPEEDING)	The engine is running with more rpm than normal which may cause mechanical damage.
Off (POWER DOWN)	The engine is switched off and is not running.

To

The electronic unit detects whether the vehicle ignition is switched on via connection point B44. This status remains active as long as no speed signal is received.

Starting

Starting is detected via the engine speed signal. The speed must be higher than a specific value, but lower than the engine speed when idling.

Idling

The electronic unit detects this status by the engine speed. The speed depends on the different operating conditions (e.g. coolant temperature).

Engine running

The engine speed is higher than a specific value.

DMCI ENGINE MANAGEMENT SYSTEM

Control functions

XF105 series

1

Cruise

If a voltage signal is received on pin B20 or B16, the electronic unit detects that the cruise control switch has been operated. There must also be a speed signal of ≥ 30 km/h present.

PTO

The PTO status is made known via a CAN message via V-CAN1 from VIC-2. The "RES" switch on the steering column switch / steering wheel switch must also be operated so that DMCI receives a CAN message from VIC-2 via V-CAN.

Overrevving

This status is detected when the engine speed is higher than a specific value.

Off

Voltage is removed from pin B44. The electronic unit detects that the ignition has been switched off.

DMCI ENGINE MANAGEMENT SYSTEM

XF105 series

Control functions

3.2 CAN CONTROLS

The DMCI engine management system communicates via V-CAN1 and V-CAN2 with various vehicle systems. DMCI is equipped with a terminating resistor for V-CAN1 and V-CAN2.

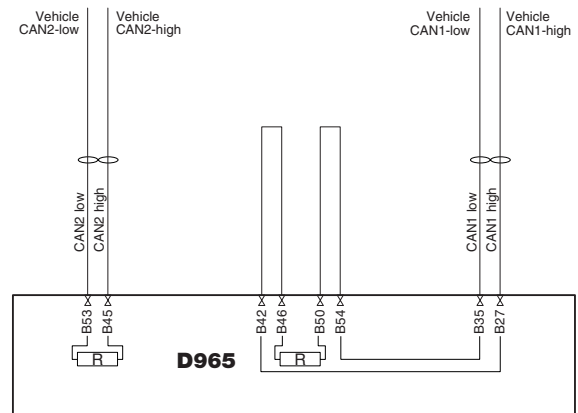

i400994

DMCI	
V-CAN1	V-CAN2
VIC-2	VIC-2
EAS	DIP-4
AS Tronic	BBM
Immobiliser	MTCO / DTCO
	ZF retarder EST-42
	ABS-D
	EBS-2
	ECAS-4

The DMCI electronic unit receives relevant information from other electronic units and sends information to these electronic units in its turn. Communication with DAVIE XD takes place via the D-CAN to VIC-2 and via VIC-2 and V-CAN1 again to DMCI. A number of important CAN messages are shown below.

DMCI ENGINE MANAGEMENT SYSTEM

Control functions

XF105 series

1

Received CAN messages:

- request to activate the PTO/engine speed control via application connector (BBM)
- immobiliser identification code to release fuel supply (immobiliser)
- activation of ABS (EBS-2/ABS-D)
- activation of ASR (EBS-2/ABS-D)
- activation of ZF intarder (EST-42)
- vehicle speed signal (MTCO/DTCO)
- activation of cruise control (VIC-2)
- activation of PTO/engine speed control via steering column switch (VIC-2)

Sent CAN messages:

- red and yellow fault messages (VIC-2)
- coolant temperature (VIC-2)
- engine speed (DIP-4, EAS, EBS-2, etc.)
- engine torque (EAS, EBS-2, AS Tronic)
- inlet air boost pressure (VIC-2)
- engine oil pressure (VIC-2)
- accelerator pedal position (ZF-intarder)
- engine brake activation (AS Tronic)
- activation of parking brake (VIC-2)
- status of variable vehicle speed limiting (VIC-2)
- status of vehicle speed limiting for special applications (VIC-2)
- fuel consumption (VIC-2)

DMCI ENGINE MANAGEMENT SYSTEM

XF105 series

Control functions

3.3 PRE-GLOWING AND AFTER-GLOWING

The purpose of the glowing system is to warm up the inlet air so that the engine starts up more easily and so that the engine runs more smoothly if the outside temperature is low. During pre-glowing, the inlet air is heated before the engine starts. Glowing can also take place while the engine is starting. After-glowing takes place when the engine is running. Pre-glowing and glowing when starting mean that the engine starts smoothly. Glowing when starting and after-glowing reduce emissions (white smoke) in cold conditions.

Depending on the number of input signals, the electronic unit determines whether pre-glowing and possibly after-glowing are necessary. If the ignition is switched on then the electronic unit compares the following temperatures:

- coolant temperature (F566),
- inlet air temperature (F649),
- fuel temperature (F713).

If one of these three temperatures is lower than a certain programmed temperature then the electronic unit will decide to activate the glow plug relay. De laagste temperatuur van deze drie bepaalt de tijdsduur van het voorgloeien. Voorgloeien zal altijd gevolgd worden door gloeien tijdens starten.

After-glowing is also determined by the lowest of the three temperature signals (coolant, inlet air and fuel). Glowing during starting and after-glowing prevents the emission of white smoke. The electronic unit provides a glow plug relay (G014) with current via pin C60, C61 and C62.

The glow relay (G014) is activated when the electronic unit switches the relay to earth via pin C32. If the glow plug relay is activated then the glow element (B341) is provided with current via the fuse (E392). At the same time the electronic unit receives a current at pin C39. The electronic unit can determine via this input whether the glowing system is active, remains active when not wanted or can not be activated. The electronic unit then sends a CAN message to VIC-2 to control the glow indication on DIP 4 or a warning on the main display.

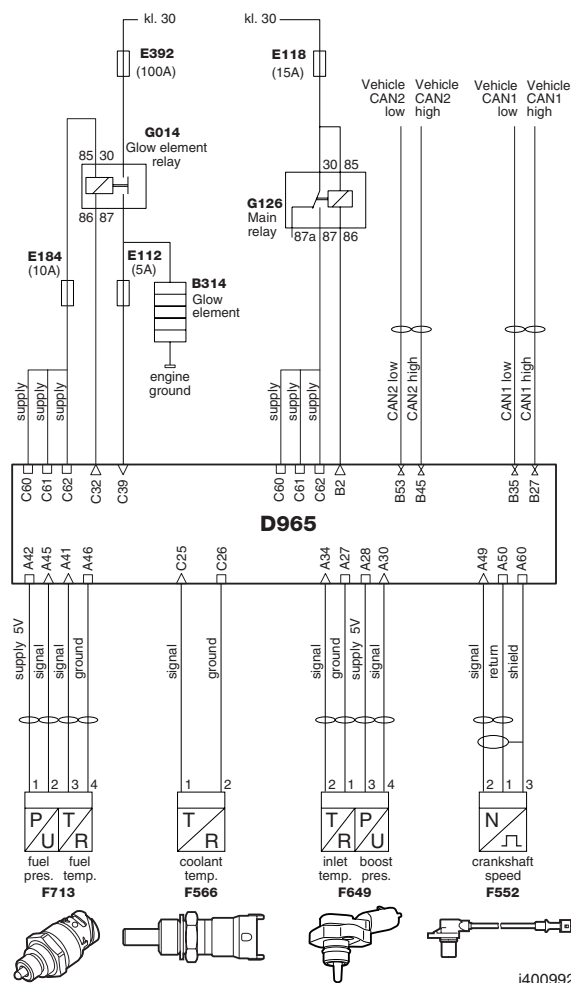

DMCI ENGINE MANAGEMENT SYSTEM

Control functions

XF105 series

1

Conditions for activating the pre-glowing function:

1. Battery voltage must be higher than a specific value and
2. one of the three temperatures (coolant, inlet air or fuel) must be lower than a specific value when the ignition is turned on, and
3. no speed signal may be present.

If pre-glowing is active, the glow indicator on DIP must be activated. The pre-glowing time is 3 minutes at most.

Conditions for activating glowing when starting:

1. When starting the engine and pre-glowing has been activated and
2. the battery voltage during starting is higher than a specific value and
3. the engine speed is lower than idling speed.

If glowing is active during starting, the glow indicator on DIP must be activated.

Conditions for activating after-glowing:

1. Battery voltage must be higher than a specific value,
2. at least one of the three temperatures (coolant, inlet air or fuel) must be lower than a specific value when the ignition is turned on, and
3. the engine speed must be higher than a specific value.

If after-glowing is active, the glow indicator on DIP must be activated. The after-glowing time is 3 minutes at most.

Relevant components

- Coolant temperature sensor (F566)
- Charge boost pressure and temperature sensor (F649)
- Fuel pressure and temperature sensor (F713)
- Crankshaft sensor (F552)
- Glow plug relay (G014)
- Glow element (B341) and
- Battery voltage (G126)
- VIC-2 (D310 via V-CAN1 and V-CAN2)

DMCI ENGINE MANAGEMENT SYSTEM

XF105 series

Control functions

3.4 IMMOBILISER AND START INTERRUPTION

The complete control consists of three functions:

- Fuel release immobiliser
- Starter motor block immobiliser
- Starter motor block if engine is running

Immobiliser

The task of the engine management system in the immobiliser system is to release and block the fuel supply and to block the starter motor. The purpose of the immobiliser is to ensure that the engine can only be started with the correct ignition key.

When the vehicle ignition is turned on, the immobiliser electronic unit reads the imcode from the ignition key and compares this to the codes (up to 5) stored in its memory. If the code is correct, the immobiliser electronic unit creates a coded CAN message and sends this via V-CAN1 to the DMCI electronic unit (D965). The DMCI electronic unit decrypts this CAN message using the stored vehicle code. If the vehicle code from the DMCI electronic unit and the vehicle code from the immobiliser electronic unit are identical, the CAN message is "approved". The DMCI electronic unit releases the fuel supply by on-going control of the pump units and injectors.

If the codes do not match or there is a fault on the CAN connection, the DMCI electronic unit will block release of the fuel supply. The pump units and injectors will then no longer be activated. The DMCI electronic unit then informs the immobiliser unit that the code was not correct and a fault code is stored in the DMCI electronic unit and the immobiliser electronic unit.

On the second attempt to start the DMCI will not earth the starter motor (B010) via B09. The starter motor will therefore not work.

If release of the fuel supply is blocked, a red fault message is activated on the DIP master display, the "STOP" lamp lights up and an acoustic signal sounds. This message is sent via a CAN message and output B22 to VIC-2.

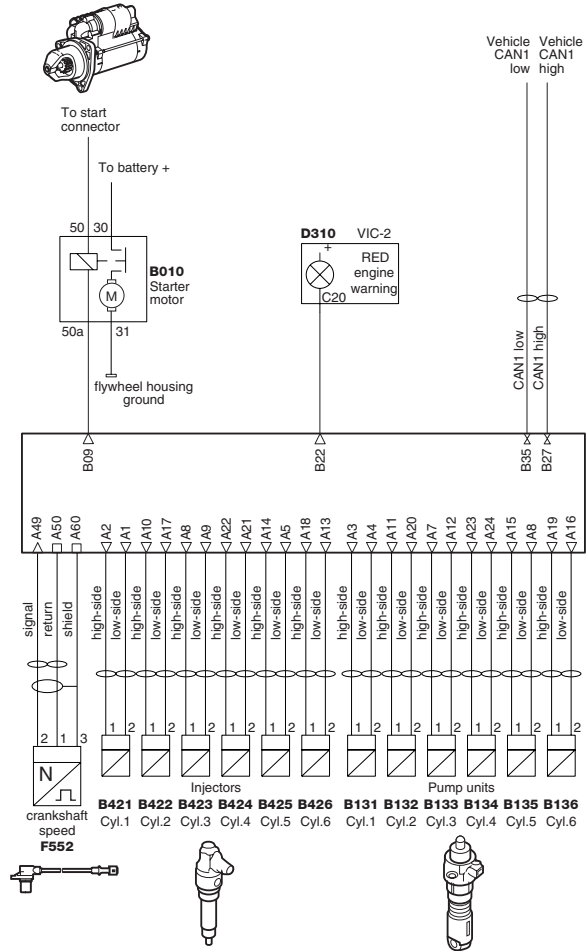

i400993

DMCI ENGINE MANAGEMENT SYSTEM

Control functions

XF105 series

Note:

Fuel is released as soon as an attempt is made to start the engine to promote a quick start. Release of the fuel supply will only be blocked if it becomes apparent that the codes do not match. So the engine may already be running before it is established that the codes do not match.

Starter motor lock

If the engine is running and the electronic unit DMCI receives an engine speed signal then DMCI will ensure that the starter motor can not be activated.

Relevant components

- Pump units (B131 to B136)
- Injectors (B421 to B426)
- Starter motor (B010)
- Immobiliser (D912 via V-CAN1)

1

DMCI ENGINE MANAGEMENT SYSTEM

XF105 series

Control functions

3.5 CYLINDER DETECTION AND SYNCHRONISATION

General

The electronic unit needs to know which cylinders are doing what and when in order to calculate the correct injection timing and the correct quantity of fuel to be injected for each cylinder. There are 3 segments on the flywheel, which each have 18 holes and an area with two holes missing. Each area with 2 holes missing indicates two cylinders that are at top dead centre at the same time (1/6, 2/5 and 3/4). From the centre of the area where two holes are missing to the actual top dead centre of the cylinder, angle β (81° crankshaft = 40.5° camshaft) is covered. 13 pulses (72° crankshaft) are emitted from the centre of hole 1 to the centre of hole 13.

The camshaft has a pulse wheel with 6 teeth for cylinder detection and an additional tooth (S) for synchronisation. These 6 teeth for cylinder detection are spaced at 60° intervals. The angle γ (15°) between the synchronisation tooth and the cylinder -1 tooth on the camshaft pulse wheel correspond to angle γ (30°) between the 14th and 15th hole and the centre of the area where two holes are missing on the crankshaft.

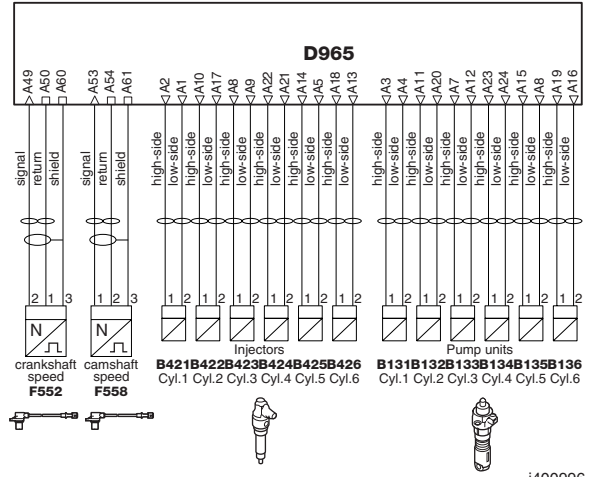

i400996

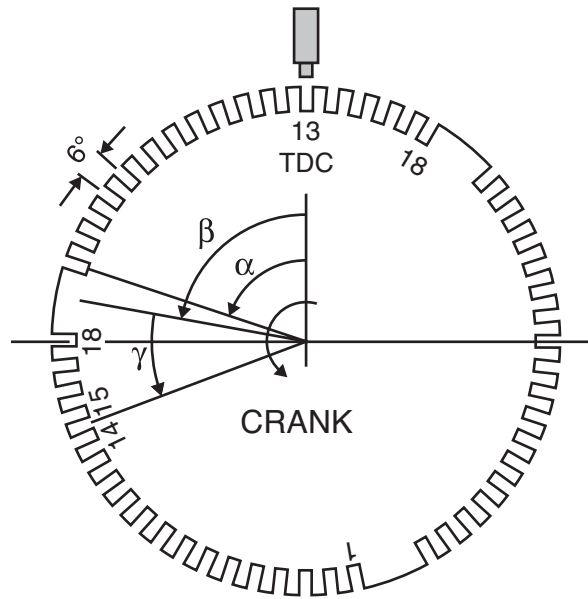
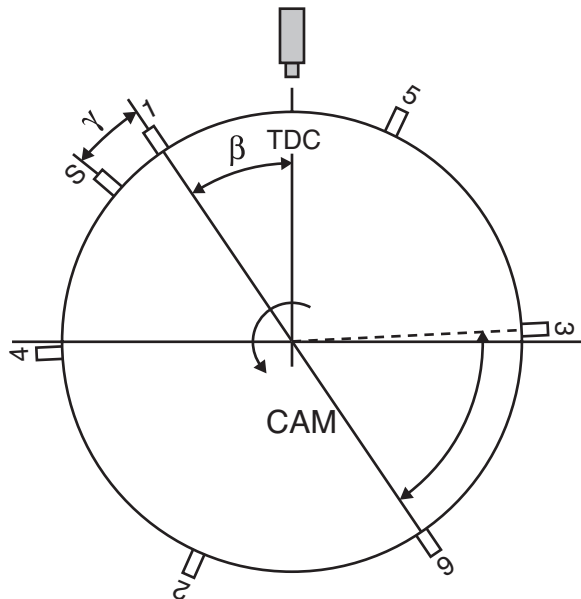

i4 00 707

$\alpha = 72^\circ$ crankshaft (crankshaft sensor 1st pulse)
 $\beta = 81^\circ$ crankshaft = 40.5° camshaft (camshaft sensor on cylinder -1 pulse)
 $\gamma = 30^\circ$ crankshaft = 15° camshaft (camshaft sensor on synchronisation pulse, crankshaft signal between 14th and 15th pulse of the previous segment)

DMCI ENGINE MANAGEMENT SYSTEM

Control functions

XF105 series

1

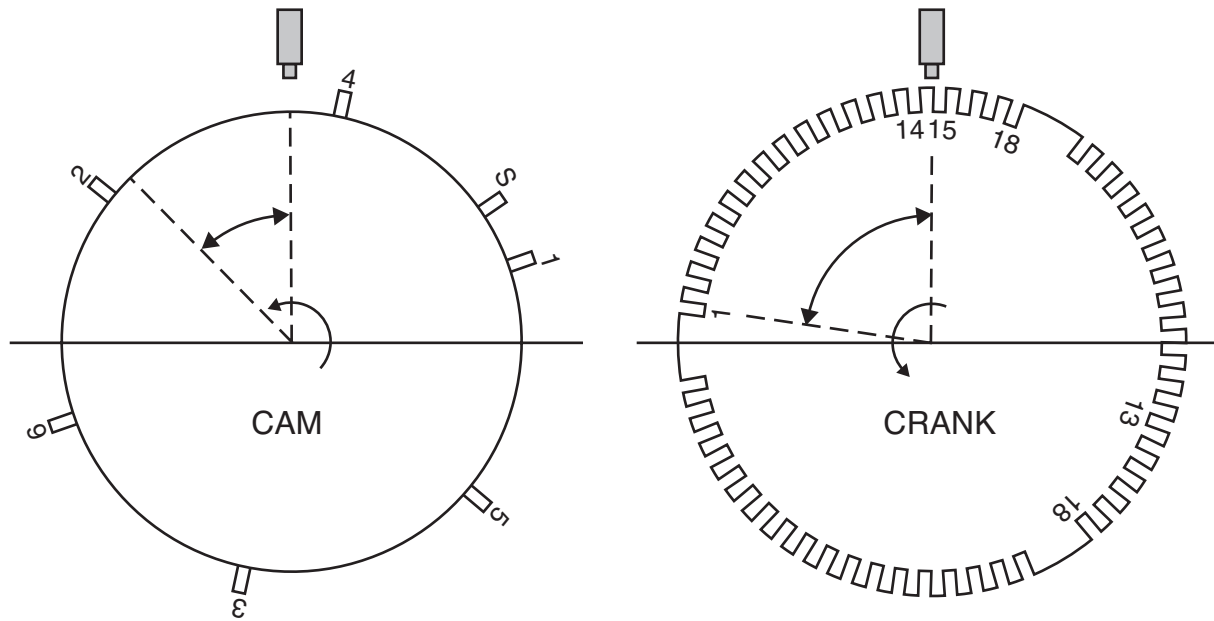

i4 00708

Synchronisation

The synchronisation procedure starts when the engine is being started. This procedure is a control for the electronic unit to detect the cylinders.

The procedure starts when the electronic unit detects a "hole" in the pulse train of the crankshaft sensor signal (F552). At that moment the electronic unit starts to count the crankshaft pulses and after the 14th and 15th pulse it immediately checks the camshaft signal (F558). If no camshaft signal is sent, the counting procedure is restarted after a "hole" in the crankshaft signal.

DMCI ENGINE MANAGEMENT SYSTEM

XF105 series

Control functions

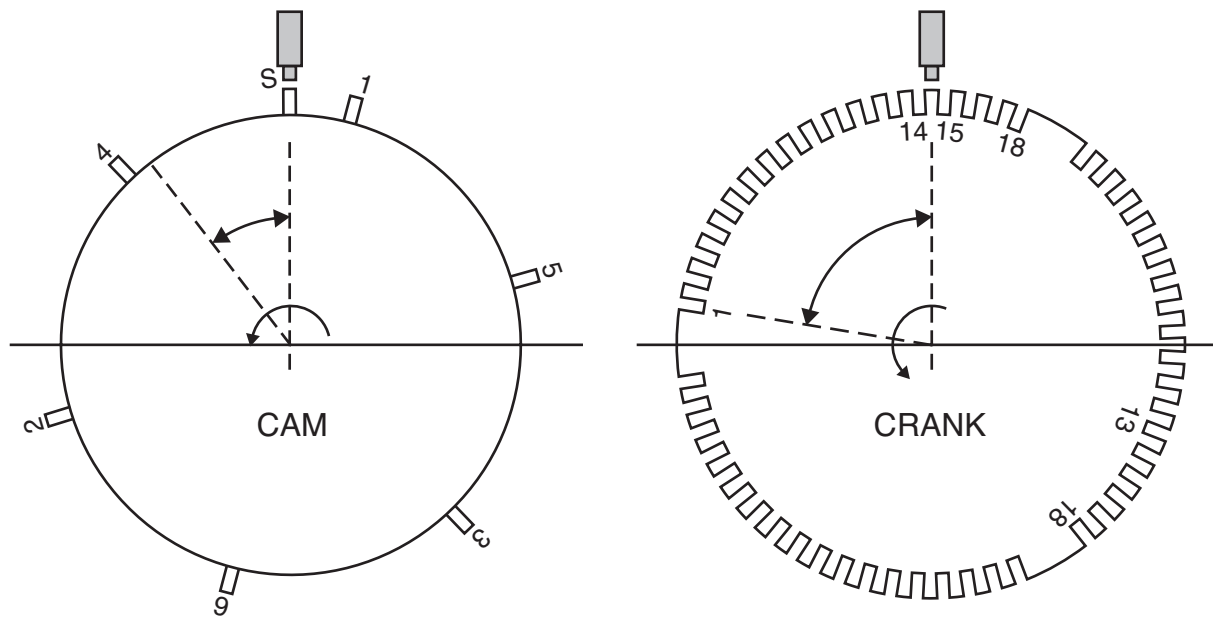

1

Synchronisation is complete when a camshaft pulse is sent by the camshaft sensor between the 14th and 15th pulse of the crankshaft signal. This pulse is the synchronisation pulse (S). The synchronisation pulse must be detected within two crankshaft revolutions. If this is not the case, this indicates that something is wrong with the timing of the engine (mechanical fault) or with the sensor signals (electrical fault). If one of the sensor signals is absent, synchronisation cannot take place.

i400709

DMCI ENGINE MANAGEMENT SYSTEM

Control functions

XF105 series

1

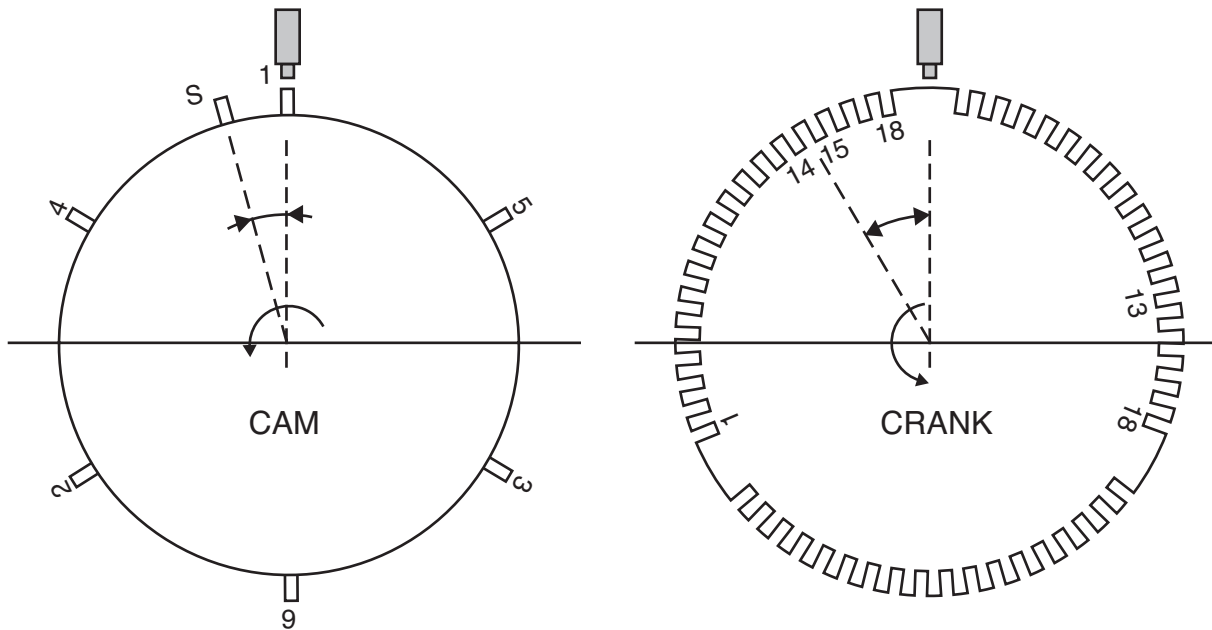

i400711

When synchronisation has taken place, the electronic unit can precisely determine which cylinder is doing what and when. The next pulse from the camshaft sensor after the synchronisation pulse (S) is that of cylinder 1. This matches the centre of the section of the flywheel in which two holes are missing (a "hole" in the crankshaft sensor signal).

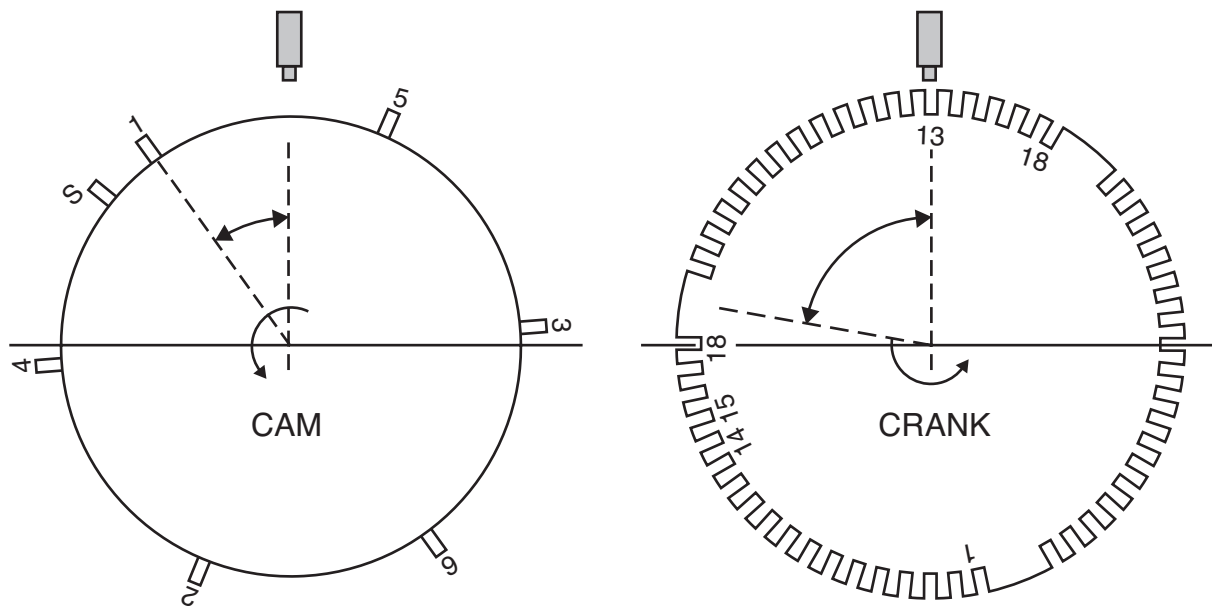

i400710

That is still 81° before the actual top dead centre (TDC) of this cylinder. The electronic unit uses this period to make all the calculations for injection procedure, injection timing and injection quantity.

Emergency procedure when starting

If the crankshaft sensor signal is absent, the engine can still start but it takes a few revolutions longer. The camshaft signal is basically sufficient for cylinder detection. The electronic unit knows that the pulse for cylinder 1 follows the synchronisation pulse (S). In this case, the injection timing is calculated less precisely, because the crankshaft sensor pulses are absent. Injection must now be calculated on the basis of time.

If the camshaft signal is absent, the electronic unit cannot detect the various cylinders solely on the basis of the crankshaft sensor signal.

The electronic unit therefore activates a pump unit/injector pair of a single arbitrary cylinder as if this is cylinder 1, a few degrees before each 13th crankshaft sensor pulse. The other pump unit / injector pairs are then activated in accordance with the injection sequence. If no crankshaft speed increase is observed by the electronic unit then it will select the next pump unit / injector pair and activate this as if it were cylinder 1. This has eventually to be the right pump unit / injector pair and an increase in the crankshaft speed will be observable. From then on, the electronic unit maintains the programmed injection sequence and the engine will start. In the worst case the recognition takes 12 crankshaft revolutions.

Emergency procedure when engine is running

If the camshaft sensor signal drops out when the engine is already running, this does not have any consequences for calculating injection.

If the crankshaft sensor signal drops out when the engine is already running, the electronic unit can no longer precisely determine when the fuel must be injected. Only one pulse per cylinder is now received from the camshaft sensor. The electronic unit must now determine the correct injection timing on the basis of time.

Relevant components

- Crankshaft sensor (F552)
- Camshaft sensor (F558)

DMCI ENGINE MANAGEMENT SYSTEM

XF105 series

Control functions

3.7 INJECTION TIMING CONTROL

The injection timing is calculated for the various different system statuses (starting, idling, part/full load, cruise and PTO). During each system status, the inlet air temperature (F649), the coolant temperature (F566), the engine speed (F552) and the calculated required quantity of fuel are taken into account as well.

The inlet air and coolant temperature are used to ensure that the emission of white smoke is kept within the limits. If the air intake temperature or the coolant temperature is lower then the injection timing will be earlier.

The moment at which the injector is controlled determines the injection timing.

Relevant components

- Coolant temperature sensor (F566)
- Charge boost pressure and temperature sensor (F649)
- Crankshaft sensor (F552)
- Injectors (B421 to B426)

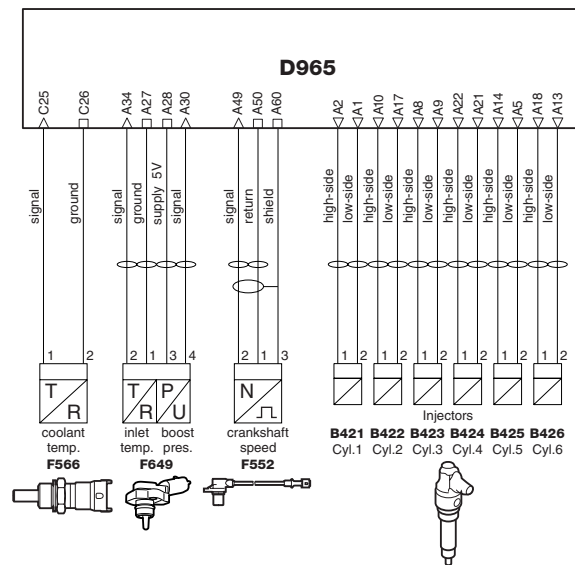

i401014

1

DMCI ENGINE MANAGEMENT SYSTEM

Control functions

XF105 series

3.8 IDLING CONTROL

The idling control ensures that the engine runs at a stable speed depending on the coolant temperature and the load on the engine. If the signal from the accelerator pedal sensor is incorrectly received or is not received, the electronic unit increases the speed ($1000 \text{ rev}/\text{min}$). This is to ensure that the vehicle can still be driven to a workshop or a safe place.

Relevant components

- Coolant temperature sensor (F566)
- Crankshaft sensor (F552)
- Accelerator pedal sensor (F672)

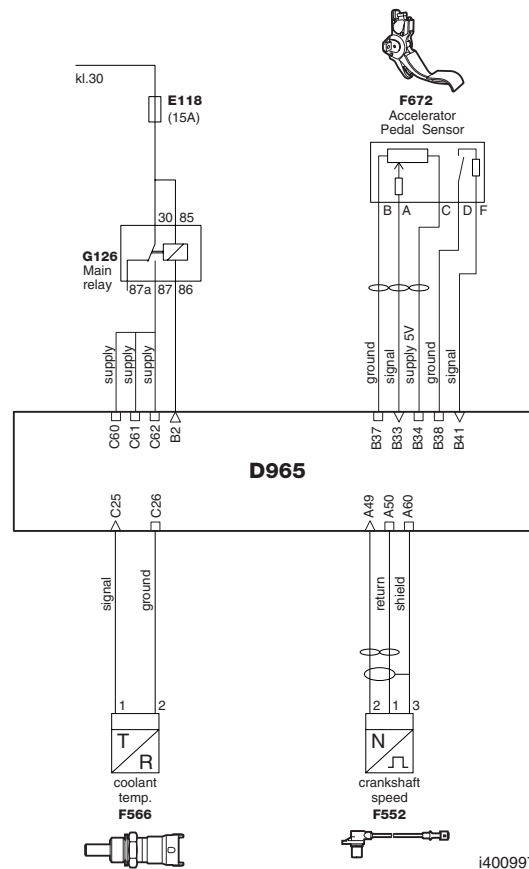

1

DMCI ENGINE MANAGEMENT SYSTEM

XF105 series

Control functions

3.9 TURBOCHARGER PRESSURE CONTROL

A waste gate is used to allow the exhaust gas flow to bypass the turbine, which reduces the drive of the turbocharger. Controlling the drive of the turbocharger, i.e. the exhaust gas flow, also controls the inlet air pressure. A conventional waste gate is adjusted so that it opens at a specific inlet air boost pressure. This is to protect the engine and the turbocharger against excessive loads. The application of an electronic control on this waste gate allows the inlet air pressure to be controlled precisely. For instance, in order to prevent too high a speed of the turbocharger it is possible to realise a relatively high boost pressure at a low speed and a relatively low boost pressure with high speeds. The waste gate is operated by a waste gate valve (B368). This valve is controlled by a duty cycle from pin C8 (10% is closed, 90% is fully open). The electronic unit calculates the required inlet air pressure depending on engine speed (F552), inlet air pressure (F649, pin A34), inlet air temperature (F649, pin A30), ambient air pressure (internal atmospheric pressure sensor) and the calculated fuel quantity.

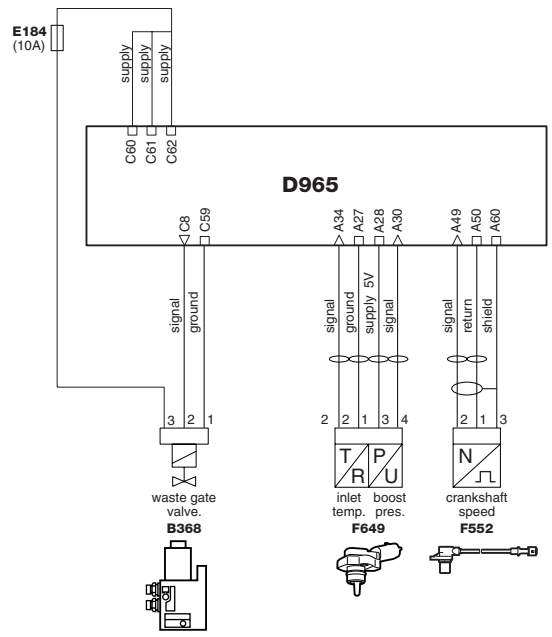

i400998

1

DMCI ENGINE MANAGEMENT SYSTEM

Control functions

XF105 series

1

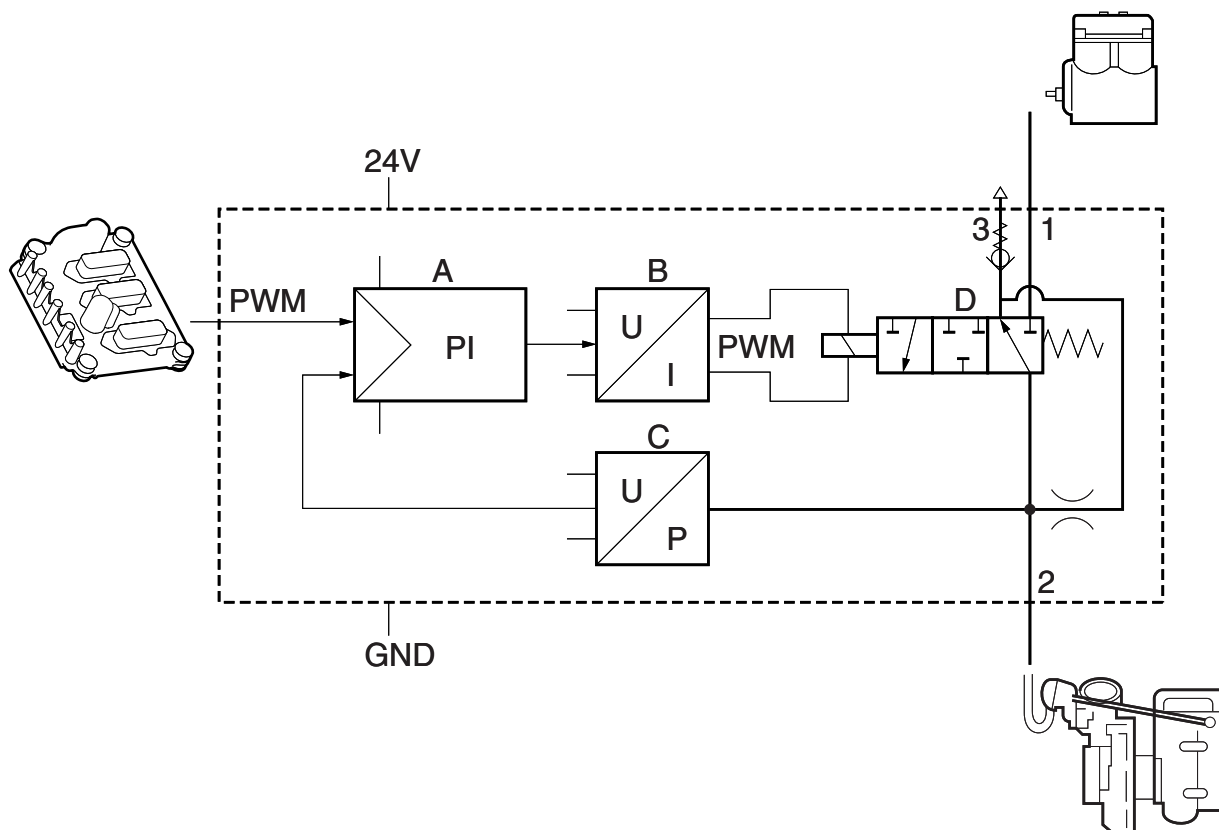

i400748

The air supply for the waste gate valve comes from air circuit 4 and is adjusted in the valve from 10 bar up to a specific control pressure depending on the duty cycle.

The electronic unit sends a duty cycle (PWM) signal to the internal electronics (A) of the waste gate valve. This signal reflects the requirements of the electronic unit. The waste gate valve also has an internal pressure sensor (C). This sensor measures the actual output pressure (2) to the waste gate. The sensor sends a signal to the internal electronics (A) of the waste gate valve. If the actual pressure measured differs at all from the requirement, the electronics (B) correct the duty cycle (PWM) to valve (D) so that the output pressure reaches the required value.

If the inlet air boost pressure and temperature sensor (F649) is defective, the waste gate valve is moved to a specific fixed "safe" position. The maximum boost pressure will not be reached in this situation.

Relevant components

- Charge boost pressure and temperature sensor (F649)
- Internal atmospheric air pressure sensor
- Crankshaft sensor (F552)
- Waste gate valve (B368)

DMCI ENGINE MANAGEMENT SYSTEM

XF105 series

Control functions

3.10 SMOKE LIMITATION

This function ensures that emissions of black smoke are kept to a minimum level. The fuel-air ratio is responsible for the development of smoke. The DMCI electronic unit calculates smoke limiting on the basis of the inlet air pressure (F649, pin A34) that is compensated by the inlet air temperature (F649, pin A30). To calculate the mass of the intake air, the electronic unit requires the inlet air temperature, the inlet air pressure and the intake air volume. The latter can be calculated on the basis of the cubic capacity and the speed of the engine. When the intake air mass has been calculated, the electronic unit can determine the maximum amount of fuel that can be injected to prevent excessive development of smoke.

If the inlet air boost pressure signal is absent or is not correct, the electronic unit carries out calculations using an air mass table based on the engine speed (F552).

Relevant components

- Charge boost pressure and temperature sensor (F649)
- Crankshaft speed sensor (F552)
- Injectors (B421 to B426)

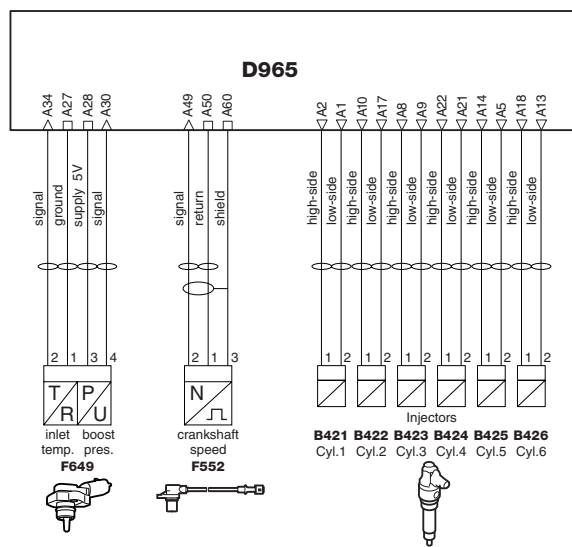

i401000

1

DMCI ENGINE MANAGEMENT SYSTEM

Control functions

XF105 series

3.11 ENGINE BRAKE CONTROL

1

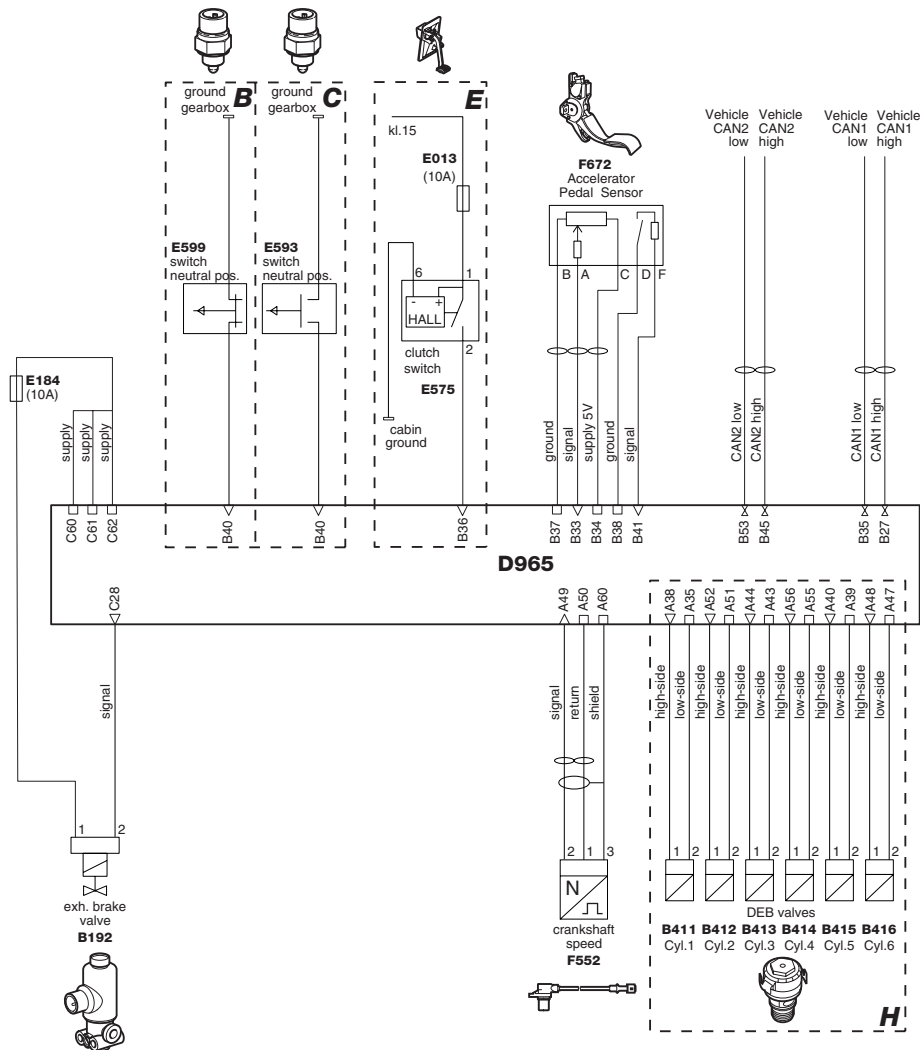

i400995

The engine brake consists of an exhaust brake and, if fitted, a DEB (DAF Engine Brake). The engine brake can be activated by the driver (direct activation) or by another vehicle system (indirect activation).

Direct activation

The vehicle can be equipped with two engine brake switches, a standard floor switch (E564) and a steering column switch (C907) if the vehicle is not equipped with an interarder. Both switches are linked to VIC-2 (D310). VIC-2 sends a CAN message to DMCI to activate the engine brake. When the CAN message is received from VIC-2 the exhaust brake valve (B192) and, if fitted, the DEB valves (B411 to B416) are actuated. However, the DCMI also takes into account other vehicle conditions (e.g. engine speed, vehicle speed and activation of ABS). When the engine brake is active, no fuel is injected until the engine speed drops to just above idling speed

DMCI ENGINE MANAGEMENT SYSTEM

XF105 series

Control functions

(approx. 800 rpm). The engine brake is then disengaged and fuel is injected again after a small delay. The DEB valves (B411 to B416) are simultaneously and continuously actuated during activation of the engine brake.

AS Tronic receives a CAN message via V-CAN1 if the engine speed is not optimal for engine brake use. If the speed is too low, AS Tronic will change down until the engine speed falls within the engine speed range for which the engine-brake capacity is optimal.

Activation via the floor switch (E564)

If the floor switch is pressed then VIC-2 sends a CAN message via V-CAN2 to DMCI to operate the engine brake.

The engine brake can only be engaged if the conditions below are satisfied:

1. The engine speed must be higher than a programmed value and
2. the vehicle speed must be higher than a programmed value and
3. the ABS control must not be active.
4. clutch pedal switch not active
5. neutral position switch not operated
6. idling switch may not be operated

1

DMCI ENGINE MANAGEMENT SYSTEM

Control functions

XF105 series

1

Activation via steering column switch (C907)

If the floor switch is not activated then the engine brake can be activated by briefly moving the steering column switch to the "ON" position (2). The steering column switch is a spring-loaded switch in this direction and returns after operation to the centre position.

Activating the engine brake using the steering column switch is only possible if the following requirements are met:

- Idling switch not active (accelerator pedal not operated)
- Cruise control switch "SET-", "SET+" and "RES" not active

The engine brake activation using the steering column switch is deactivated if one of the following requirements is met:

1. Steering column switch is in the "OFF" position (1)
2. Idling switch is active (accelerator pedal operated)
3. Cruise control switch "SET-", "SET+" and "RES" active
4. Clutch pedal depressed
5. Neutral position switch operated

Note:

The engine brake is deactivated during the activation of the clutch switch and/or the neutral position indicator (therefore not if the drive line is interrupted). If these switches are no longer active then the engine brake will be reactivated.

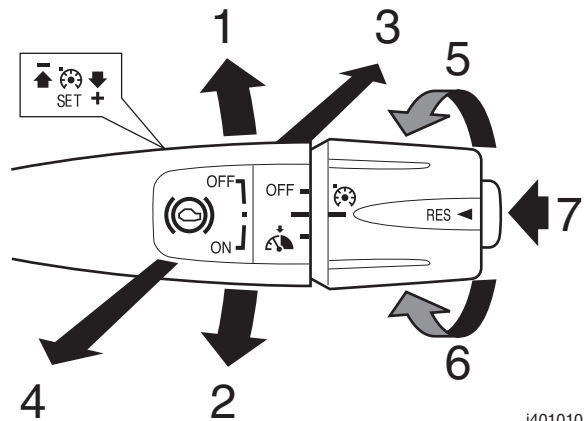

i401010

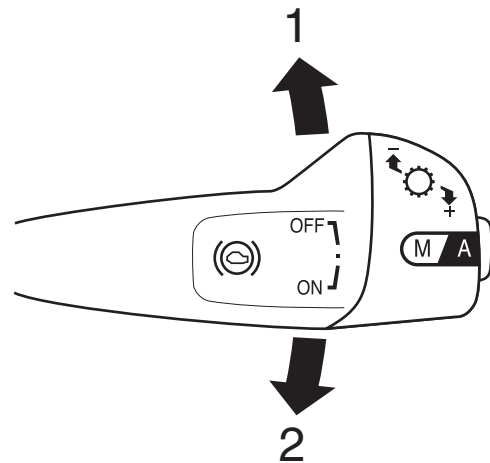

i401011

Indirect activation

The engine brake can also be activated at the request of another system such as the interarder (EST-42) and EBS-2.

- EBS-2

If EBS-2 sends the CAN message "EBS brake switch" via V-CAN2 to DMCI then DMCI will support vehicle braking by activating the engine brake.

This is the "third brake integration" function. This protects the brake lining during normal braking. This "third brake integration" function can also be deactivated using a dashboard switch.

DMCI ENGINE MANAGEMENT SYSTEM

XF105 series

Control functions

- Intarder

In the case of the intarder a CAN message is sent via V-CAN2 if the maximum brake position is selected by the driver or if the coolant temperature exceeds a certain value during intarder activation. The vehicle braking is increased through the assistance of the engine brake during the maximum intarder brake position.

If during intarder activation a programmed maximum coolant temperature is exceeded then the cooling system will be relieved through assistance from the engine brake.

Deactivation via V-CAN2

The engine brake activation can also be deactivated or blocked via a CAN message. If ABS becomes active while the service brake is being used in combination with the engine brake, the engine brake is switched off. From the ABS/EBS system the CAN message "ABS active" is sent to DMCI. DMCI will then deactivate the engine brake. When an attempt is made to activate the engine brake when ABS is active then activation of the engine brake will be blocked.

Also, if the wheels block during the use of the engine brake then a CAN message will be sent from the ABS/EBS system to DMCI to deactivate the engine brake temporarily. If the wheels turn again normally then the engine brake will be activated again.

Relevant components

- Crankshaft sensor (F552)
- Exhaust brake valve (B192)
- DEB solenoid valves (B411 to B416)
- VIC-2 (D310 via V-CAN1 and V-CAN2
 - Steering column switch (C907) via V-CAN1
 - Engine brake switch (E564) via V-CAN2

1

DMCI ENGINE MANAGEMENT SYSTEM

Control functions

XF105 series

3.12 FAN CLUTCH CONTROL

1

The purpose of the fan is to keep the coolant temperature below a specific maximum value. The valve in the fan clutch (B335) is opened or closed depending on various sensors. The fan clutch has a constant power supply of 24 V and is connected to earth with a duty cycle via pin C16. A high duty cycle means decreasing fan speed. A low duty cycle means increasing fan speed. The internal fan speed sensor feeds back the current fan speed to the DMCI electronic unit on pin C36. The electronic unit determines whether the fan clutch must be actuated more or less depending on this signal.

Note:

The fan always runs at high speed for a specific period after the engine is started. This is because some of the silicone fluid has settled and is in the working chamber. If the silicone fluid is cold as well, the fan will run at high speed for some time.

A number of different variables are taken into account in the fan clutch control:

1. coolant temperature (F566)
2. Air inlet temperature (F649)
3. retarder activation (via V-CAN2);
4. vehicle speed (via V-CAN2)
5. internal slip protection.

Coolant temperature

From a specific coolant temperature (a), the minimum actuation of the fan clutch increases evenly with the coolant temperature. When a specific higher coolant temperature (b) is reached, the fan clutch is immediately actuated to maximum. If the coolant temperature drops again following this, actuation stays maximum until a specific lower coolant temperature (c) is reached and then decreases again evenly as the coolant temperature decreases.

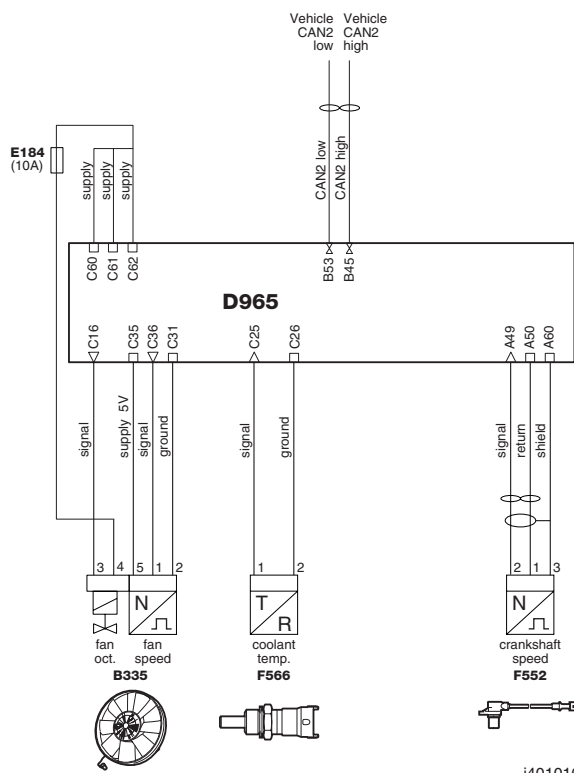

i401016

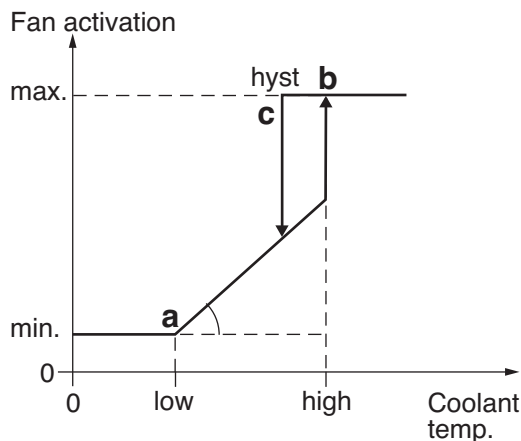

i400833

DMCI ENGINE MANAGEMENT SYSTEM

XF105 series

Control functions

1

Activation of retarder

Two controls are used during activation of the retarder. A control that activates a time delay to control the fan clutch and a control that activates the fan clutch depending on the requested intarder braking power.

- Intarder braking power

If the required braking power of the intarder is higher than a specific value, the intarder electronic unit will actuate the DMCI electronic unit to activate the fan clutch. This is to prevent excessive temperatures. The electronic unit will only increase actuation of the fan clutch above a specified low coolant temperature (a). Above a specified high temperature (b), the fan clutch is actuated to maximum.

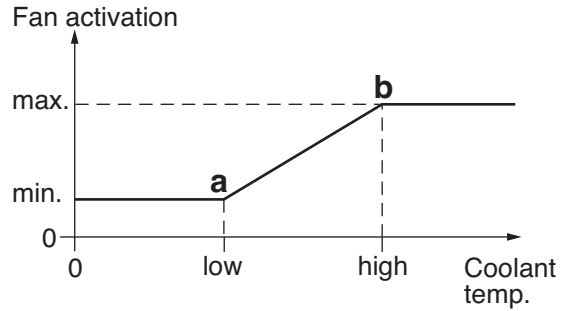

i400834

- Time delay

Depending on the current coolant temperature at the time the intarder is activated, the fan clutch is switched on either with or without a delay. If the coolant temperature is low, the fan clutch will only be activated after a few seconds (a). If the coolant temperature is high, the fan clutch will be activated with a short delay (b).

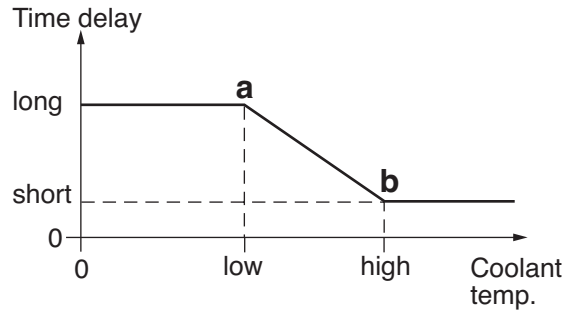

i400830

Vehicle speed

When the vehicle speed is low, there is little cooling from the air stream. Making activation of the fan clutch dependent on vehicle speed prevents the coolant temperature in the engine rising too rapidly. If the vehicle is stationary or is driving at low speed, the fan clutch will be activated with a high fan speed. Up to a specific vehicle speed (a), the fan speed will remain high and will then gradually decrease to a specific minimum fan speed at a specific higher vehicle speed (b).

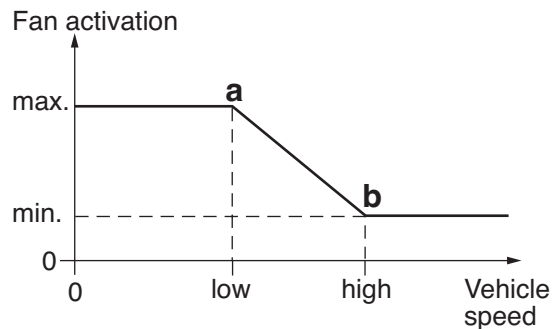

i400829

DMCI ENGINE MANAGEMENT SYSTEM

Control functions

XF105 series

internal slip protection

If the engine speed is high ($> 2000 \text{ rev}/\text{min.}$) and the fan clutch speed is low, the viscous fluid may burn as a result of internal slip. In order to protect the viscous fluid from excessive temperatures, a specific speed range of the fan clutch is not used. If a fan speed (a) is reached at which there is the risk of the viscous fluid overheating, the fan clutch will not be actuated further. Only when a specific required speed (b) is reached will actuation increase to a maximum value. This means that the calculated required speed between a and b is not used. When the fan clutch actuation is maximum, the slip is minimum and the fan speed is maximum. If the required fan speed drops again, the fan clutch actuation stays maximum until a specific required speed (c) is reached, at which point actuation drops to level (a).

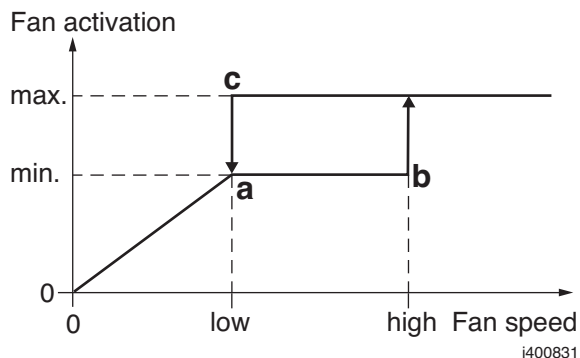

Relevant components

- Coolant temperature sensor (F566)
- Charge boost pressure and temperature sensor (F649)
- Crankshaft sensor (F552)
- Intarder EST-42 (D902 via V-CAN2)
 - Intarder active
- Tachograph (B525 via V-CAN2)
 - Vehicle speed signal
- Electronically controlled fan clutch (B335)

1

DMCI ENGINE MANAGEMENT SYSTEM

XF105 series

Control functions

3.13 ENGINE PROTECTION FUNCTIONS

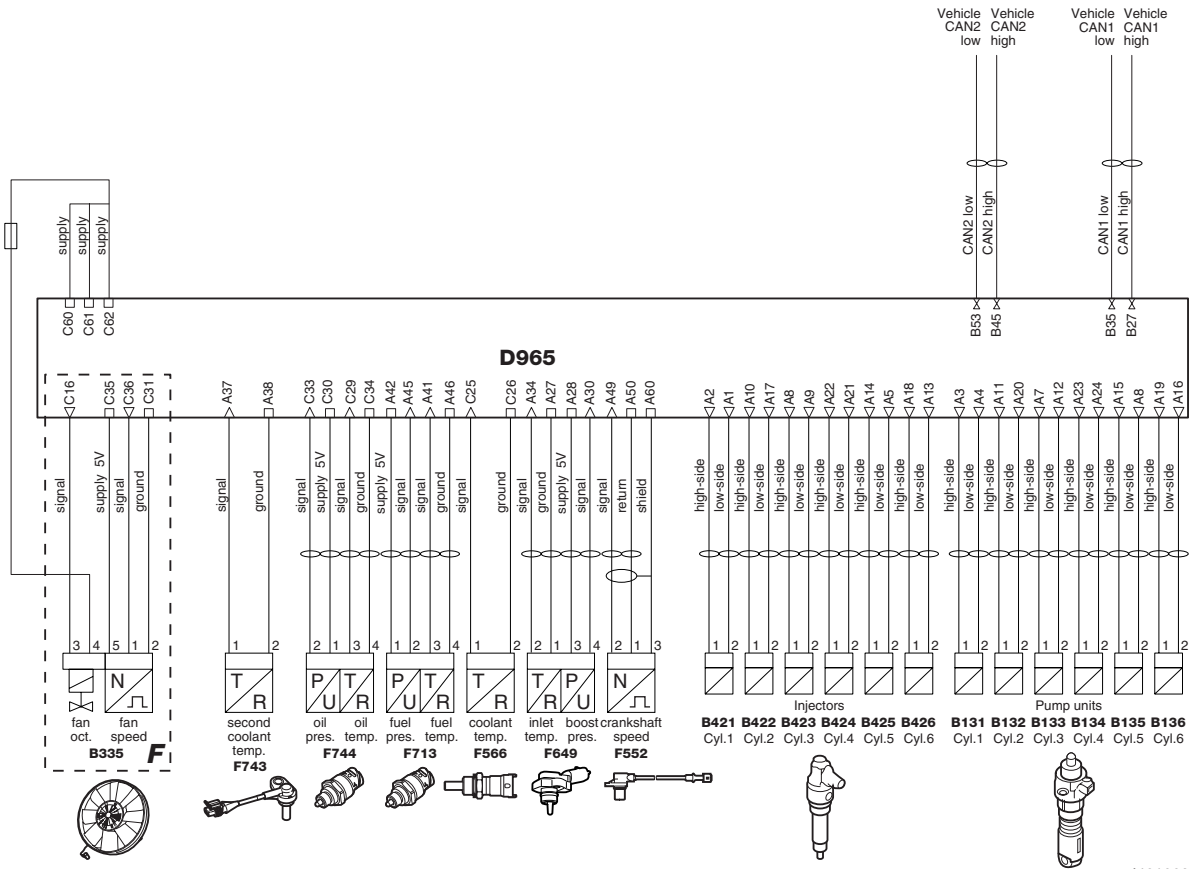

The general task of this function is to limit the requested quantity of fuel, related to the engine speed, atmospheric pressure, coolant temperature and other engine/vehicle conditions. The controls ensure that the engine and drive train are not mechanically and/or thermally overloaded. The engine torque is limited or reduced for this purpose. The protection functions can be sub-divided into two groups:

- Thermal engine protection
- Mechanical engine protection

Thermal engine protection

1. Cooling problem detection
2. Over-heating protection
3. Exhaust gas temperature limitation

Mechanical engine protection:

1. Turbocharger protection
2. Height correction
3. PTO/engine speed control torque limiting
4. Fuel temperature correction
5. Engine oil pressure protection
6. Engine speed protection when engine is cold
7. Excess engine speed detection

DMCI ENGINE MANAGEMENT SYSTEM

Control functions

XF105 series

1

Thermal engine protection

1. Cooling problem detection

The aim is to prevent over-heating due, for example, to a non-functioning coolant pump because of a broken poly-V-belt or a blockage or leak somewhere in the cooling system. This detection is active when the engine has been running for a certain time, the engine speed is higher than a certain value and the measured temperature from both temperature sensors (F566 and F743) is higher than a certain value. There are three ways in which a cooling problem can be detected:

- When the temperature difference between the two temperature sensors (F566 and F743) is higher than a certain value (F566 is located at cylinder 1 and F743 is located at cylinder 6). Too great a difference in temperature between cylinders 1 and 6 could mean that the coolant pump is not functioning properly.
- When the signal from the second coolant temperature sensor (F743) rises too much within a certain time. A rapid rise on coolant temperature at cylinder 6 could mean that the coolant pump is not functioning correctly.
- When no engine speed signal is received from the electronically-controlled fan clutch (B335). This could mean that the Poly-V belt is broken and that therefore the coolant pump is no longer operating.

If DMCI has recognised the cooling problem then the injected fuel will be limited so that the engine will be able to supply less torque. The yellow engine warning will also be activated.

Relevant components

- Coolant temperature sensor (F566)
- Second coolant temperature sensor (F743)
- Electronically-controlled fan clutch (B335)
- Crankshaft sensor (F552)
- Pump units (B131 to B136)
- Injectors (B421 to B426)

2. Over-heating protection

If the coolant temperature (F566) exceeds a specific maximum value, the maximum quantity of fuel to be injected is reduced. Heat development will be less as less energy is put into the engine.

Relevant components

- Coolant temperature sensor (F566)
- Pump units (B131 to B136)
- Injectors (B421 to B426)

3. Exhaust gas temperature limitation

The objective is to limit the exhaust gas temperature by limiting the maximum quantity of fuel to be injected and therefore to protect the turbine of the turbo against over-heating. This limit is a calculation of the exhaust manifold temperature, the maximum permissible exhaust gas temperature and the air flow through the engine. This function is active above a certain engine speed and account is taken of the warming up of the turbo housing.

Relevant components

- Charge boost pressure and temperature sensor (F649)
- Crankshaft sensor (F552)

Mechanical engine protection

1. Turbocharger protection

a. Protection against too high a boost pressure
To protect the turbocharger against overrevving and to protect the engine against excessive mechanical loads, the torque is reduced if the boost pressure of the engine becomes (much) too high. The electronic unit uses engine speed (F552) and charge boost pressure (F649) signals to calculate whether the compressor speed and/or the engine load is likely to become too high. Too high a speed of the turbocharger at a specific engine speed (for instance when the waste gate of the turbocharger is not functioning) may cause an excessive boost pressure. If the turbocharger speed becomes too high, the compressor wheel will deform too much and lubrication of the shaft will be inadequate; this may cause damage. To prevent this, less fuel is injected at this point and consequently the exhaust gas flow is reduced. The turbocharger speed will automatically become lower.

Relevant components

- Crankshaft sensor (F552)
- Charge boost pressure and temperature sensor (F649)
- Pump units (B131 to B136)
- Injectors (B421 to B426)

DMCI ENGINE MANAGEMENT SYSTEM

Control functions

XF105 series

1

b. Protection against too high a temperature
To protect the turbocharger against excessive exhaust gas temperatures, the injected quantity of fuel is reduced when the temperature of the exhaust gas becomes too high. The exhaust gas temperature is calculated by the electronic unit; it is not measured by a sensor. The electronic unit uses the engine speed (F552), charge boost pressure and charge temperature (F649) to make this calculation.

Relevant components

- Crankshaft sensor (F552)
- Charge boost pressure and temperature sensor (F649)
- Pump units (B131 to B136)
- Injectors (B421 to B426)

2. Height correction

Depending on the height (low atmospheric pressure), a maximum quantity of fuel to be injected is calculated. A decrease in the "quantity of air supplied" by the turbocharger as the vehicle is driven at a specific height may result in high exhaust gas temperatures. If the air is thinner, the quantity of fuel to be injected is adjusted, i.e. reduced, accordingly.

Relevant components

- Crankshaft sensor (F552)
- Internal atmospheric pressure sensor
- Pump units (B131 to B136)
- Injectors (B421 to B426)

3. PTO/engine speed control torque limiting

During the various engine speed control functions via the steering column switch and the application connector ("nvar", "n2", "n3"), the quantity of injected fuel can be limited to protect against overload of any PTO-driven components. This is a torque limiting function where the limiting percentage can be programmed with the aid of DAVIE XD. See also the control function "Engine speed control" and the document "Test and customer parameter information DAVIE XD".

Relevant components

- Crankshaft sensor (F552)
- PTO torque limiting active (software - customer parameters)
- Pump units (B131 to B136)
- Injectors (B421 to B426)

4. Fuel temperature correction

When the fuel temperature is low, the density is high. This means that there is more "energy" in the quantity of injected fuel. The engine could become thermally and also mechanically overloaded as a result. This can be avoided by adjusting the quantity of fuel to be injected in relation to the fuel temperature (F713).

Relevant components

- Fuel pressure and temperature sensor (F713)
- Pump units (B131 to B136)
- Injectors (B421 to B426)

5. Engine oil pressure protection

If the engine oil pressure (F744) drops below a specific minimum value, the maximum speed is limited. Also, a warning is activated in the DIP main display.

Relevant components

- Engine oil pressure and temperature sensor (F744)
- Crankshaft sensor (F552)
- Pump units (B131 to B136)
- Injectors (B421 to B426)
- VIC-2 (D310 via V-CAN1)

6. Engine speed protection when engine is cold

The engine speed limitation is active when the engine is started and the coolant temperature is under a certain value. From that moment a limited maximum engine speed (1500 rpm) will be maintained for a certain time (maximum 30 seconds).

Relevant components

- Coolant temperature sensor (F566)
- Crankshaft sensor (F552)
- Pump units (B131 to B136)
- Injectors (B421 to B426)

7. Excess engine speed detection

It is possible that the engine speed will exceed the maximum engine speed during a descent. If the engine speed exceeds the maximum engine speed by too much then engine over-speed will be detected. At that moment an error code which can not be erased by the dealer and the duration of the engine over-speed are stored in the electronic unit. At the same time a warning is shown on the display "Engine speed too high".

Relevant components

- Crankshaft sensor (F552)
- VIC-2 (D310 via V-CAN1)

DMCI ENGINE MANAGEMENT SYSTEM

Control functions

XF105 series

3.14 VEHICLE SPEED LIMITING FUNCTIONS

There are three possible vehicle speed limitations:

- Statutory vehicle speed limitation (standard)
- Variable vehicle speed limitation (optional)
- Vehicle speed limitation for special applications (optional)

When this function is active, the DMCI electronic unit adjusts the injection of fuel so that the programmed vehicle speed cannot be exceeded irrespective of the position of the accelerator pedal.

Vehicle speed limitation laid down by law
 Legally prescribed vehicle speed limiting is a programmed speed that is prescribed by law. This speed is programmed in the factory and can only be changed by special request and at your own risk.

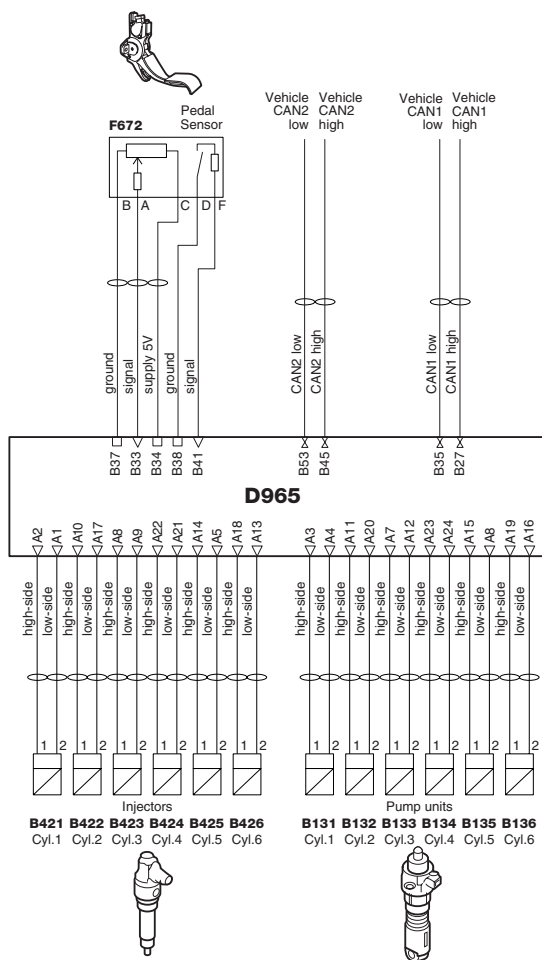

i401002

Variable vehicle speed limitation

The variable vehicle speed limitation can be activated by way of the steering column switch (C907 - 5) or the "SET" button of the steering wheel switch (C916 - 1). The function can only be activated if the vehicle speed is higher than 30 km/h. At the moment that the rotary switch of the steering column switch (C907 - 5) is turned downwards or the "SET" button of the steering wheel switch (C916 - 1) is operated then the vehicle speed at that moment is stored in the DMCI electronic unit as the variable limiting speed. DMCI receives a CAN message from VIC-2 for this.

The set variable limiting vehicle speed is shown in the master display of the instrument panel. It will not be possible to exceed the limiting speed irrespective of the position of the accelerator pedal.

Steering column switch C907

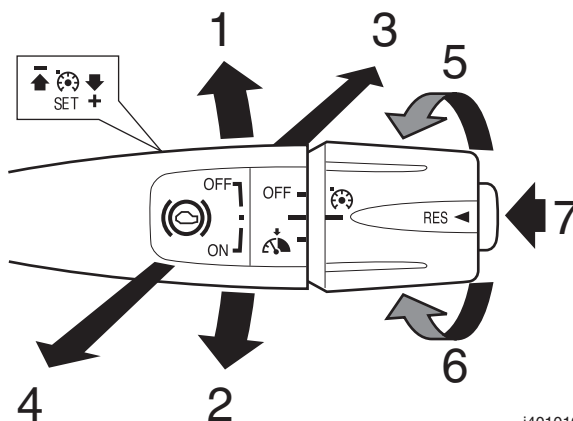

i401010

DMCI ENGINE MANAGEMENT SYSTEM**XF105 series**

Control functions

The speed can be increased by briefly operating the "SET+" (C907 - 4) or the "+" button (C916 - 5). The speed can be decreased by briefly operating the "SET-" (C907 - 3) or the "(C916 - 6) button. The speed is adapted in increments of 0.5 km/h each time the "SET+/" or "SET-/" switch is operated. If the "SET+/" or "SET-/" switch is operated for longer, the speed can be increased using the accelerator pedal.

For safety reasons, it is important that this function can be (temporarily) switched off quickly, for example when overtaking. This occurs when the "kick-down" function is activated by depressing the accelerator pedal fully. When the speed drops back down to the set variable vehicle speed limit, the function is automatically activated again.

The function is deactivated by turning the steering column switch (C907) to the centre position (6) or by operating the "OFF" button (C916 - 2) of the steering wheel switches. If an error occurs in the vehicle speed signal, the function is automatically switched off.

Vehicle speed limiting for special applications

This is a programmed speed that is used for a special application (such as footboard protection for a refuse-collection vehicle). The function is activated via a connection point (4 - "v max appli.") on the application connector (A068), the refuse-collection vehicle connector (A095) or by a switch in the cab.

When this function is active, the vehicle speed cannot exceed the programmed speed irrespective of the position of the accelerator pedal. This programmed speed can be changed using DAVIE XD. The standard speed is 30 km/h. When this function is active, the vehicle speed will vary by no more than +/- 1 km/h and the acceleration speed is reduced.

If an error occurs in the vehicle speed signal, the function is automatically switched off.

Relevant components

- VIC-2 (D310 via V-CAN1)
 - Steering column switch (C907 via V-CAN1)
 - Steering wheel switches (C916 via V-CAN1)
- BBM (via V-CAN2)
 - Application connector, engine speed control (A068 pin 4)
 - Refuse-collection vehicle connector (A095 pin 4)
- Tachograph (B525 via V-CAN2)
 - Vehicle speed signal
- Accelerator pedal sensor (F672)
- Pump units (B131 to B136)
- Injectors (B421 to B426)

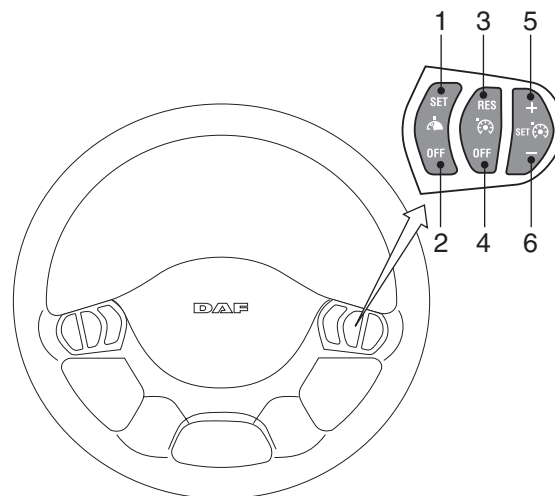
Steering wheel switches C916

K102021

1

DMCI ENGINE MANAGEMENT SYSTEM

Control functions

XF105 series

3.15 CRUISE CONTROL

1

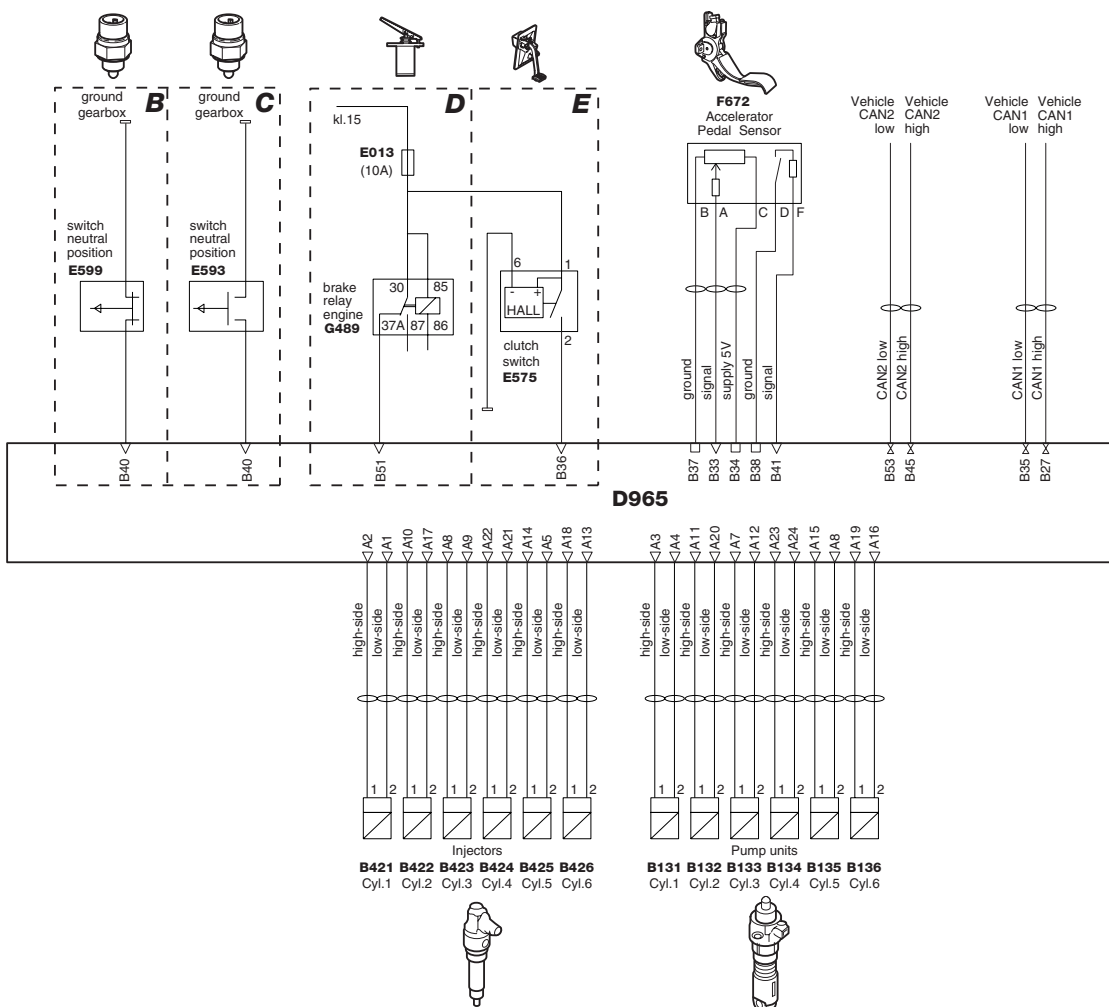

When the cruise control function is active, the set vehicle speed is automatically maintained without operating the accelerator pedal.

The function is activated by the steering column switch (C907) in the case of a manual shift vehicle or by the steering wheel switches (C916) in the case of an AS Tronic. By operating "SET +" (C907 - 4 / C916 - 5) or "SET-" (C907 - 3 / C916 - 6), the DMCI receives a CAN message from VIC-2 via V-CAN1. The current vehicle speed is then stored as the cruise control speed. The function can also be activated using the "RES" (C907 - 7 / C916 - 3) switch (Resume). The vehicle will then maintain the speed that was used when the cruise control function was last active. If the vehicle ignition has been switched off in the meantime, the "RES" speed is erased and cruise control cannot be switched on using the "RES" switch.

Steering column switch C907

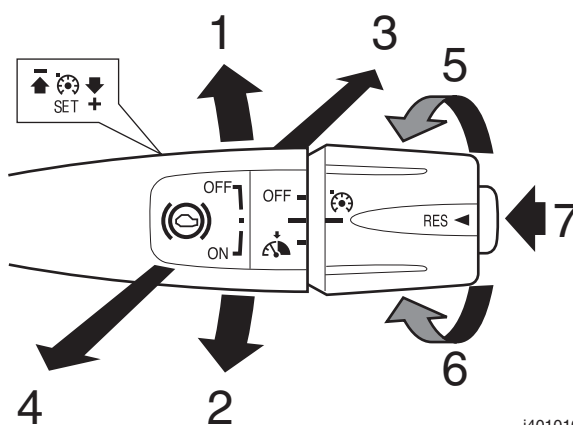

i401001

i401010

DMCI ENGINE MANAGEMENT SYSTEM

XF105 series

Control functions

While the cruise control function is active, the speed can still be changed by operating the "SET+" (C907 - 4 / C916 - 5) and "SET-" (C907 - 3 / C916 - 6) switches. By briefly operating these switches, the speed is adjusted by 0.5 km/h. If the "SET+" (C907 - 4 / C916 -5) switch is operated for a longer period, the speed increases at a specific rate if that is physically possible at that moment (gradients, load, etc.). If the "SET-" (C907 - 3 / C916 - 6) switch is operated for a longer period, the speed decreases at a specific rate if that is physically possible at that moment (gradients, load, etc.). When the cruise control function is active, the speed can be increased above the cruise control speed using the accelerator pedal. If the accelerator pedal is then no longer operated and the vehicle speed falls to the cruise control speed, the cruise control speed will again be maintained.

Steering wheel switches C916

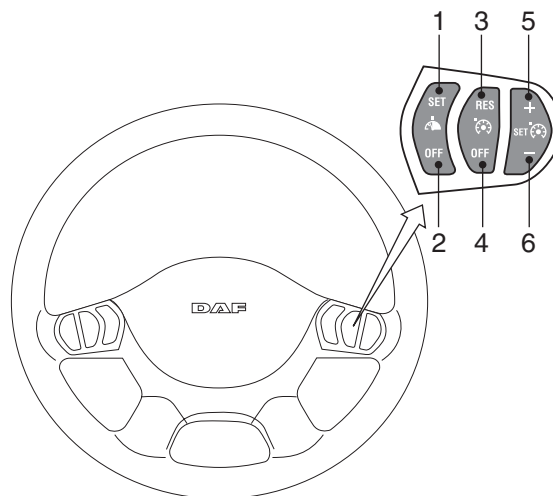

K102021

Conditions for activation

Cruise control can only be activated if:

- The "OFF" switch is not operated and
- speed is ≥ 30 km/h (depending on the programmed "v max" setting for special applications) and
- there are no errors in the vehicle speed signal and
- no brake function (service brake, parking brake, engine brake and intarder) is active and
- the clutch is not operated and
- variable vehicle speed limiting is not active and
- no errors have been detected in the steering column / steering wheel switch and
- vehicle speed limiting for special applications is not active.

Note:

During the "Downhill Speed Control" function the cruise control function will not switch off.

1

DMCI ENGINE MANAGEMENT SYSTEM

Control functions

XF105 series

Conditions for deactivation

Cruise control is switched off when:

- The "OFF" switch is operated or
- the vehicle deceleration is $>2 \text{ m/s}^2$ or
- the vehicle speed becomes lower than 25 km/h (depending on the programmed "v max" setting for special applications) or
- an error is present in the vehicle speed signal or
- one of the brake functions (service brake, parking brake, engine brake and intarder) is active or
- the clutch is operated or
- variable vehicle speed limiting is switched on or
- an error occurs in the "SET+/SET-" switch or
- vehicle speed limiting for special applications is switched on or
- the ASR control becomes active or
- the VSC control becomes active.

Relevant components

- Stop light relay/brake signal relay (G469)
- Clutch proximity switch (E575)
- Accelerator pedal sensor (F672)
- Injectors (B421 to B426)
- Pump units (B131 to B136)
- EBS-2 (D977 via V-CAN2)
- ABS-D (D850 via V-CAN2)
- ZF intarder EST-42 (D902 via V-CAN2)
- VIC-2 (D310 via V-CAN1 and V-CAN2)
 - Steering column switch (C907 via V-CAN1)
 - Steering wheel switches (C916 via V-CAN1)
 - Parking brake switch (F000 via V-CAN1)
 - Engine brake switch (E564 via V-CAN2)
- BBM (D993 via V-CAN2)
 - Application connector engine speed control (A068 via V-CAN2)

1

DMCI ENGINE MANAGEMENT SYSTEM

XF105 series

Control functions

3.16 DOWNHILL SPEED CONTROL

The Downhill Speed Control is a speed control which ensures that it is possible to drive downhill at a constant speed. The vehicle must be equipped with steering wheel switches (C916) and the combination DEB (DAF Engine Brake) with an AS Tronic gearbox. If the vehicle is equipped with an intarder then only the intarder is used for this function, see "System and components information ZF intarder EST42".

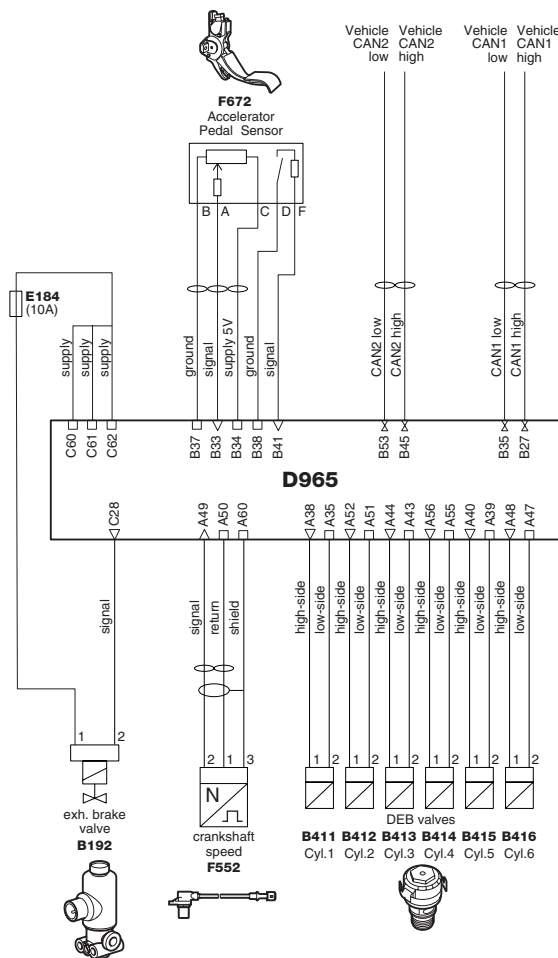

i401015

By operating the switch (5) "SET" a CAN message is sent to VIC-2 which then sends a CAN message to DMCI. The speed of the vehicle at that moment is stored in DMCI as the desired Downhill Speed Control speed. DMCI will first control the exhaust brake valve (B192). If the speed then decreases then the DEB valves (B411 to B416) will also be controlled to maintain the desired Downhill Speed Control speed. A CAN message will also be sent to AS Tronic to select the right gear for the optimum speed range for the engine brake operation.

Steering wheel switches C916

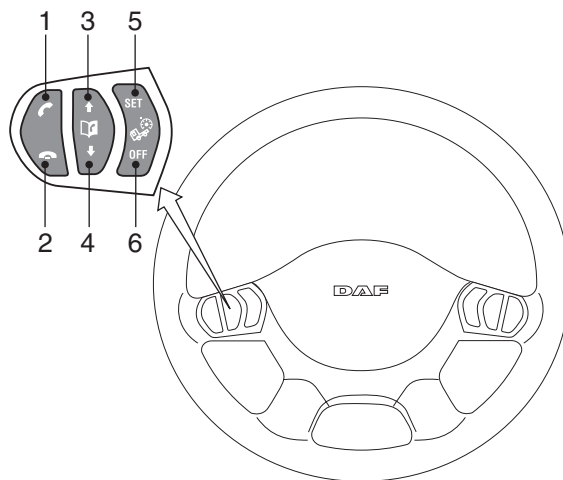

K102020

DMCI ENGINE MANAGEMENT SYSTEM

Control functions

XF105 series

1

If the cruise control is also active then the Downhill Speed Control speed will be ± 3 km/hour higher than the cruise control speed. The function can only be activated if the vehicle speed is higher than a certain value.

If the speed decreases then DMCI will first deactivate the DEB valves to maintain the desired Downhill Speed Control speed. If the speed decreases further then the exhaust brake valve will also be deactivated.

If Downhill Speed Control is active then it is possible to brake with the service brake without the Downhill Speed Control being deactivated. The exhaust brake valve and possibly the DEB valves then stay active until the speed falls under the Downhill Speed Control speed. If the speed then increases above the Downhill Speed Control speed then the exhaust brake valve is then first activated and the DEB valves if the speed continues to increase.

Conditions for activation

Downhill Speed Control can only be activated if:

- the "OFF" switch (6) is not operated and
- the speed is ≥ 30 km/h (depending on the programmed "v max" setting for special applications) and
- there are no errors in the vehicle speed signal and
- the clutch is not operated and
- no errors have been detected in the steering wheel switch and

Note:

During the "Downhill Speed Control" function the cruise control function will not switch off.

DMCI ENGINE MANAGEMENT SYSTEM

XF105 series

Control functions

Conditions for deactivation

Downhill Speed Control will be deactivated if:

- the "OFF" switch (6) is operated or
- the speed is < 25km/h (depending on the programmed "v max" setting for special applications) or
- faults occur in the vehicle speed signal or
- if the accelerator pedal is operated for a certain time and the speed is higher than the Downhill Speed Control speed and without interrupting the drive line or
- errors are detected in the steering wheel switch.

Note:

During the "Downhill Speed Control" function the cruise control function will not switch off.

Relevant components

- Accelerator pedal sensor (F672)
- DEB solenoid valves (B411 to B416)
- Exhaust brake valve (B192)
- Crankshaft sensor (F552)
- VIC-2 (D310 via V-CAN1)
 - Steering wheel switches (C916 via I-CAN)
- AS Tronic (D954 via V-CAN1)

1

DMCI ENGINE MANAGEMENT SYSTEM

Control functions

XF105 series

3.17 ENGINE SPEED CONTROL

1

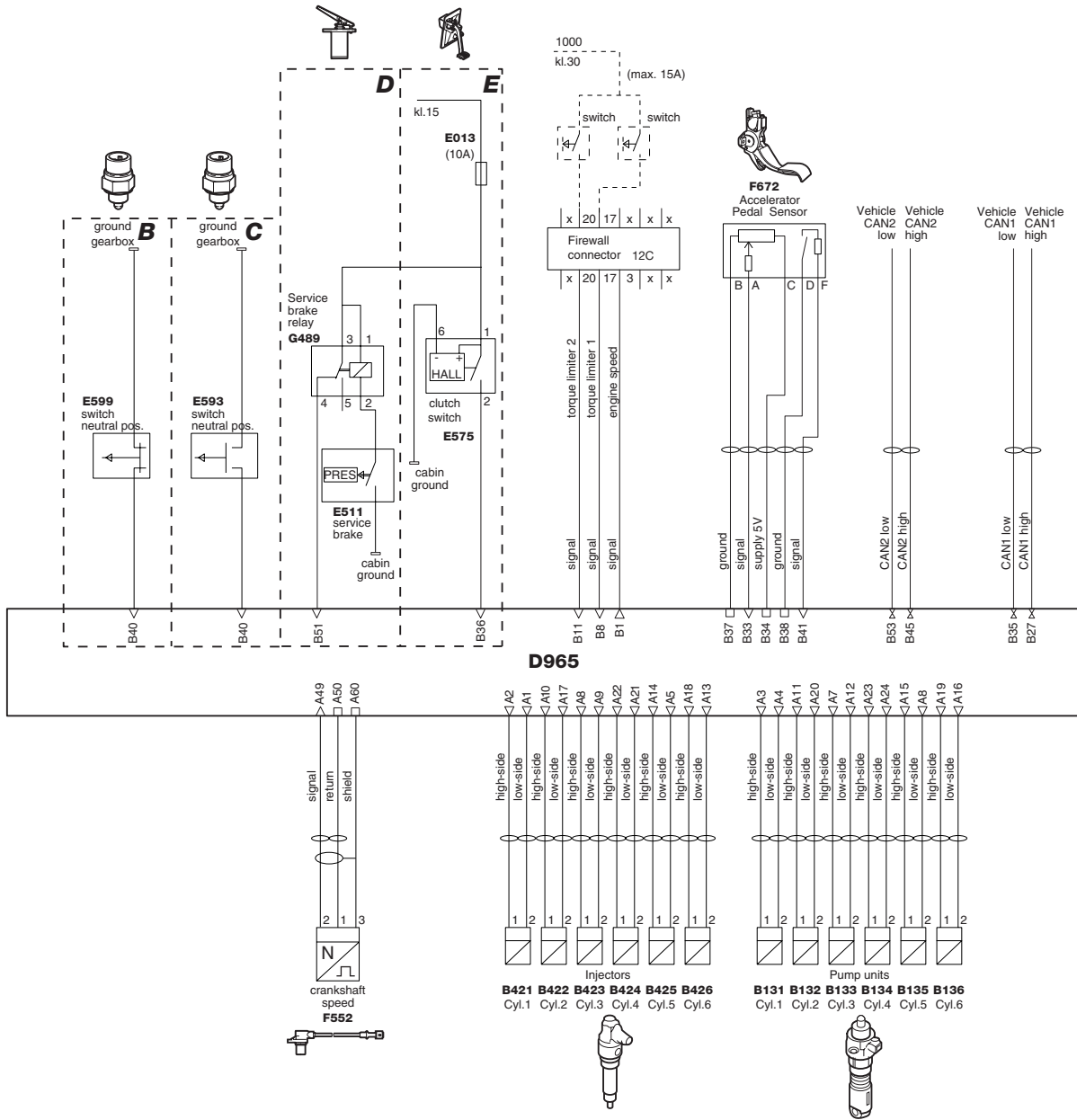

i401008

DMCI ENGINE MANAGEMENT SYSTEM

XF105 series

Control functions

Engine speed control

The purpose of this function is to set a constant, temporary engine speed higher than the idling speed. This function can be used when the vehicle is stationary and when driving. The function is activated via the steering column switch (C831), the steering wheel switches (C916) or by means of the application connector (A068).

The application connector (A068) is linked to the builder module BBM (D993). The BBM in turn sends a CAN message via V-CAN2 to the DMCI electronic unit (D965). The application connector functions have priority over steering column / steering wheel switch functions.

The switching-on and switching-off conditions have been programmed into the DMCI electronic unit; see the document "DAVIE XD test and parameter information" for a full description of these conditions.

The following components/input signals determine whether the engine speed control can be activated depending on the programmed customer parameter setting:

1. service brake signal (G469)
2. clutch signal (E575)
3. accelerator pedal sensor (F672)
4. parking brake signal (F000 via VIC-2 V-CAN1)
5. engine brake signal (E564 via VIC-2 V-CAN2)
6. current engine speed (F552).
7. the actual vehicle speed (via tachograph V-CAN2)

Activation

The engine speed control can be activated in two ways using the steering column switch (C907) and the steering wheel switches (C916):

1. by operating the "RES" key (C907 - 7 / C916 - 3).
2. by operating the "SET+" (C907 - 4 / C916 - 5) briefly once.

Steering column switch C907

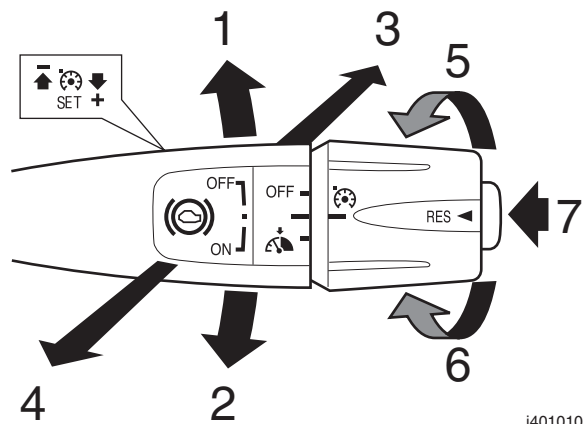

i401010

Steering wheel switches C916

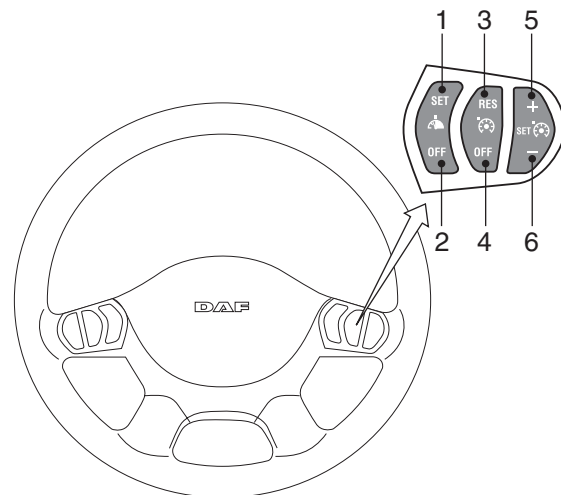

K102021

Steering column switch C907

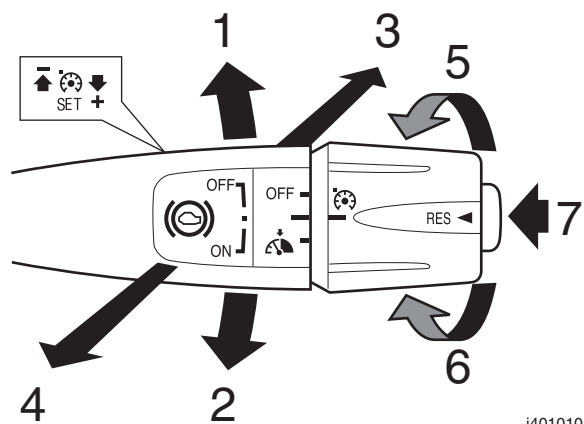

i401010

DMCI ENGINE MANAGEMENT SYSTEM

Control functions

XF105 series

1

Activation through the "RES" function

When "RES" is operated then at that moment the engine speed is increased to a programmed value in the electronic unit. When "RES" is operated again the engine speed is increased to the second programmed value in the electronic unit. After this, operating "RES" again will ensure that the engine speed decreases again to the first programmed engine speed value.

Note:

The programmed engine speed and the acceleration to reach that speed can be changed using DAVIE XD.

Activation through the "SET+" function

By operating "SET+" the engine speed will increase in steps of 25 rpm (programmable through DAVIE XD) each time it is activated or, if it is continuously operated, then the engine speed will increase evenly. The engine speed can then be reduced by operating "SET-".

This functions only if the current speed is greater than or equal to the programmed minimum engine speed in the engine speed control.

Increasing or decreasing the engine speed

If the engine speed control is activated then the engine speed can be lowered by operating the "SET-". By operating "SET+" the engine speed is increased. The engine speeds that can be set are limited by a programmed minimum and maximum value in the electronic unit.

Note:

The programmed minimum and maximum engine speed for this control and the engine speed increase/decrease per operation of the "SET+" or "SET-" can be changed using DAVIE XD.

Steering wheel switches C916

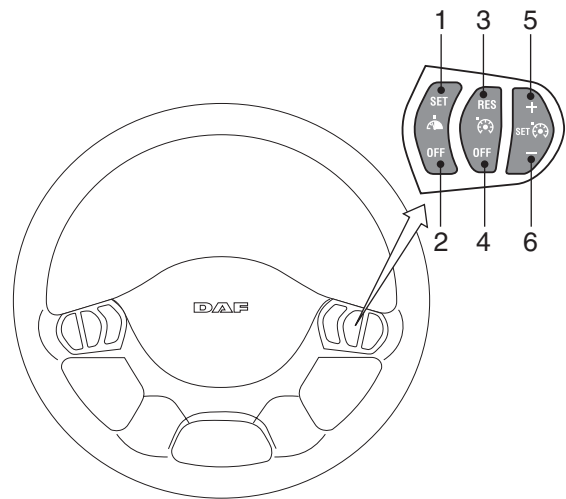

K102021

DMCI ENGINE MANAGEMENT SYSTEM

XF105 series

Control functions

Deactivation of engine speed control

1. On operation of the "OFF" function (C907 - 6 / C916 - 4) or,
2. if the engine brake is operated, or
3. if the programmed switching-on conditions are no longer satisfied, or
4. if the vehicle is driven while the engine speed control function is active and the vehicle speed is higher than a specific maximum programmed speed (e.g. when going downhill), or
5. if the engine speed drops below the minimum value (due to an increase in engine load), or
6. if the engine speed goes above the maximum value (due to a decrease in engine load).

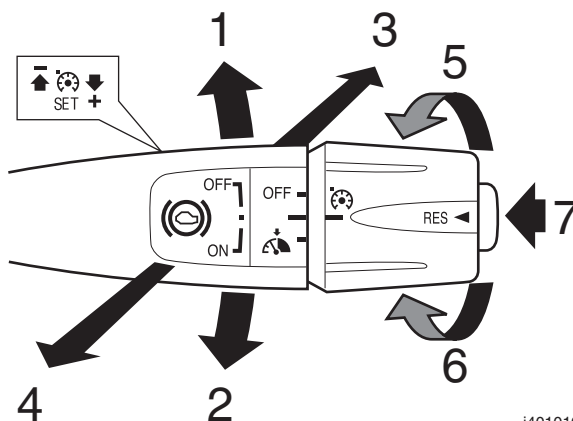

i401010

Note:

If the engine speed control has been activated via the application connector (A068), this has priority over activation via the steering column switch (C907) or the steering wheel switches (C916).

Engine torque limitation

There are three different versions of engine torque limitation:

1. Torque limiting during engine speed control
2. Multi-step torque limitation during engine speed control

1. The engine torque limitation during engine speed control can be programmed using DAVIE XD. A certain percentage of the maximum engine torque is then available. This allows PTOs and the components driven by PTO to be protected against overload. For a detailed description of this engine torque limitation see the document "Test and customer parameter information DAVIE XD".

2. In the engine speed control function, the engine torque can be limited to protect PTO-driven components against overload. Three different torque limitations are available for this function by providing current to B11 and/or B8. These torque limitations are fixed maximum torque values with a maximum engine speed limitation of 1500 rpm, see the table. This engine torque limitation is not programmable using DAVIE XD and must be released on special request.

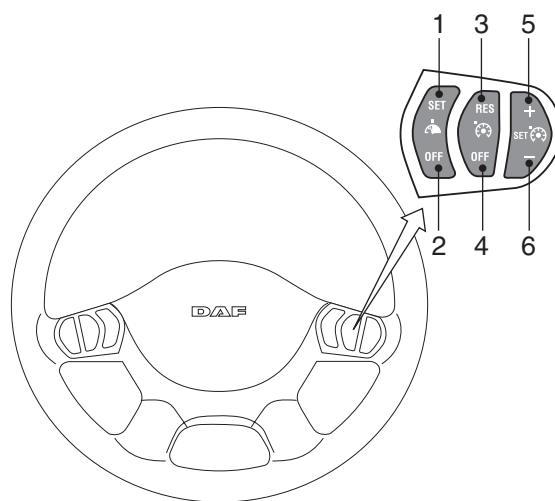

K102021

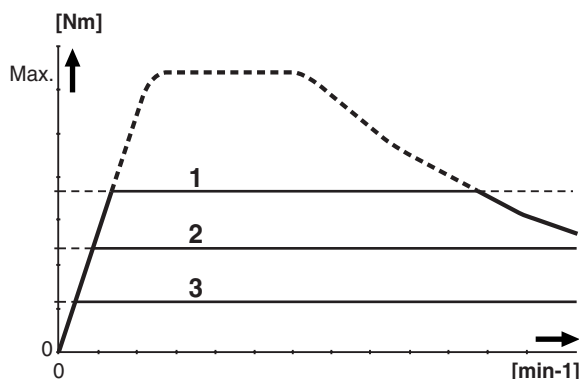

i401019

DMCI ENGINE MANAGEMENT SYSTEM

Control functions

XF105 series

		Multi-step torque limitation
Connection point B8	Connection point B11	Torque limiting during engine speed control
Ubat	0	Level 1: 1800 Nm
0	Ubat	Level 2: 1200 Nm
Ubat	Ubat	Level 3: 600 Nm

Relevant components

- Brake signal relay (G469)
- Neutral position switch (E593 / E599)
- Clutch proximity switch (E575)
- Accelerator pedal sensor (F672)
- Crankshaft sensor (F552)
- Injectors (B421 to B426)
- Pump units (B131 to B136)
- BBM (D993)
 - Application connector, engine speed control (A068)
- VIC-2, (D310)
 - Parking brake switch (F000)
 - Engine brake switch (E564)
 - Steering column switch (C831)
 - Steering wheel switches (C916)

1

DMCI ENGINE MANAGEMENT SYSTEM

XF105 series

Diagrams

4. DIAGRAMS

4.1 KEY TO BLOCK DIAGRAM DMCI

Basic code	Description
B010	Starter motor
B131	Solenoid valve, cylinder 1 pump unit
B132	Solenoid valve, cylinder 2 pump unit
B133	Solenoid valve, cylinder 3 pump unit
B134	Solenoid valve, cylinder 4 pump unit
B135	Solenoid valve, cylinder 5 pump unit
B136	Solenoid valve, cylinder 6 pump unit
B192	Exhaust brake valve
B335	Electronically controlled fan clutch
B341	Glow element
B368	Waste gate valve
B411	Solenoid valve, cylinder 1 DEB
B412	Solenoid valve, cylinder 2 DEB
B413	Solenoid valve, cylinder 3 DEB
B414	Solenoid valve, cylinder 4 DEB
B415	Solenoid valve, cylinder 5 DEB
B416	Solenoid valve, cylinder 6 DEB
B421	Solenoid valve, injector 1
B422	Solenoid valve, injector 2
B423	Solenoid valve, injector 3
B424	Solenoid valve, injector 4
B425	Solenoid valve, injector 5
B426	Solenoid valve, injector 6
D310	VIC-2 electronic unit
D965	DMCI electronic unit
E013	Fuse, brake lights
E112	Fuse, glow indicator light
E118	Fuse, engine management power supply
E184	Fuse, additional functions
E392	Glow element fuse
E511	Stop light switch
E593	Neutral position switch (manual gearbox)
E575	Proximity switch, clutch

1

DMCI ENGINE MANAGEMENT SYSTEM

Diagrams

XF105 series

1

Basic code	Description
E599	Neutral position switch (AS Tronic)
F552	Crankshaft sensor
F558	Camshaft sensor
F566	Coolant temperature sensor
F649	Inlet air boost pressure and temperature sensor
F672	Accelerator pedal sensor
F673	Engine oil level sensor
F713	Fuel pressure and temperature sensor
F743	2nd coolant temperature sensor
F744	Engine oil pressure and temperature sensor
G014	Glow plug relay
G126	Engine management supply relay
G426	Contact relay
G469	Brake signal relay

4.2 BLOCK DIAGRAM DMCI

Block diagram i400940 applies to:

- XF105

Explanation of block diagram

- A Version with glowing system
- B Version with AS Tronic
- C Version with manual gearbox
- D Version with ABS-D
- E Version with manual gearbox
- F Version with electronically-controlled fan clutch (depending on engine output, in combination with ZF intarder standard)
- G Version with electronic waste gate control (depending on engine output)
- H Version equipped with DEB

DMCI ENGINE MANAGEMENT SYSTEM

Diagrams

XF105 series

1

